

121,561

PATENT



SPECIFICATION

Application Date, Apr. 10, 1918. No. 6131/18.

Complete Accepted, Dec. 24, 1918.

COMPLETE SPECIFICATION.

New Process for the Generation of Electrical Energy.

I, CARLOS BENTEZ, Civil Engineer, of 141, Ocampo Street, in Guadalajara, Mexico, do hereby declare the nature of this invention and in what manner the same is to be performed, to be particularly described and ascertained in and by the following statement:—

5 This invention relates to a new utilisation of the high frequency currents or electrical oscillations, by means of which a constant production of electrical energy can be secured, under unusually simple, economic and practical conditions.

10 Such results are attained by means of the procedure disclosed in present applicant's English Patent Specification No. 14,311, filed on October 9th, 1915, but in order to obtain a better utilisation of said high frequency currents, and the automatic operation of the mechanisms employed in such procedure, I have invented a novel arrangement of parts, from which are derived several other advantages that will be hereinafter described and set forth with particularity in the claims appended hereto.

15 Synthetically, in such procedure so improved, are employed two batteries of accumulators, and one of these batteries is supposed that has been previously charged by proper means. Afterwards same said battery discharges through a circuit, in which are provided means for the utilisation of the greater part of the power produced by such discharge, and the remnant of same power is slunted from said circuit, into an oscillatory circuit in which the second battery is connected. Said oscillatory circuit is furthermore provided with a rectifier, which properly directs the electrical oscillations in such a manner, that they are forced to pass constantly through said second battery from the positive to the negative pole. On the other hand, as in such oscillatory circuits the number of oscillations per second can be varied at will, the current strength developed by these oscillations can be accordingly regulated, and thus the complete charge of the second battery can be produced in the same lapse of time in which the first battery discharges. Therefore it is only question of reversing the connections of said batteries from time to time and to repeat the same procedure, in order to obtain a continuous production of electrical energy.

30 The invention is illustrated in the annexed drawing in which: Figure 1 shows the circuit connexions of the arrangement and a perspective view of a commutator; Figure 2 is a lateral view of a part of same apparatus; and Figures 3 and 4 are parts of same machine, whose location and use will be hereinafter explained.

35 Same figures are employed to designate corresponding parts throughout the views.

[Price 6d.]



In Figure 1 are depicted two batteries of accumulators 1—2 and 3—4 connected in series, but obviously any other connection can be used, and no matter what arrangement is employed, their positive poles 23, 25, are joined through the ammeters 22, 24, with the terminals 17, 20, of the commutator.

Such commutator consists of a cylinder 5, mounted on a rotative shaft 6, passing through two different supports 7 and 8, and same cylinder is provided with the conductive paths 9, 10, 11, 12, conveniently insulated and distributed on its surface. Furthermore same said cylinder is provided with the conductive paths 14 and 15, that can be better seen on the cross sectional view shewn by Figure 2. Said paths made of metallic strips bent in the arc of a circle, are fixed at one of the ends of same cylinder, and are arranged to make contact with the brushes 17, 18, 19, 20, properly insulated and fixed to a ring 16, which encircles the above mentioned cylinder 5, and is fastened to the same base of the apparatus.

Said brushes are provided with their corresponding sockets, into which can be fitted plug connectors from the above described batteries and further apparatus as follows: terminal 17 is connected as above stated, with the positive pole 23 of battery 1—2; terminal 20 is connected through the ammeter 24, with the positive pole 25 of battery 3—4; terminal 18 is connected through the wire 26, with the terminal 27 of a direct current motor, whose terminal 28 is joined through the adjustable resistance 29 and the wire 30, with the terminal 31 of the commutator; and finally terminal 19 is connected through the wire 32, with the valves 33, 34, of an electrolytic rectifier, whose other two valves 35, 36, are connected by means of the conductor 37, with the terminal 38 of same commutator.

This apparatus is furthermore provided with the terminal 39, which is alternatively connected with the negative poles of each one of the above mentioned batteries, through the brushes that can be seen in the figure in contact with the cylinder 5. Under these conditions the apparatus 40 and 41, which are employed to produce a practical purpose independent of the running of the "plant;" and which are connected to both terminals 31, 39, will be alternatively in circuit with the discharging battery, and thus part of the power produced by such discharge; will be utilised by said apparatus without impairing the normal running of the whole mechanism, as will be hereinafter explained.

On the other hand, an alternator 42, is coupled to the above mentioned motor 27—28, which in this manner can be rotated at a proper speed in order to attain the desired frequency. Both terminals of said alternator are connected through the inductive resistance 43, with the poles 44, 45, of the primary of a step up transformer, whose secondary 46—47, duly connected to the condenser 48, will finally produce the high tension alternating currents required for the charge of said condenser. However the use of said motor and alternator, is not at all indispensable in this process, and the same results could be attained if the primary 44—45 of the transformer joined to an ordinary interrupter, be directly connected to the discharging battery.

The terminals 49, 50, of such condenser are connected through an arc-lamp of the Poulsen type 51—52, or through an adequated spark-gap with the above mentioned rectifier 33, 34, 35, 36, and hence with the battery that should be charged, which at the instant depicted by the figure is the battery 3—4. Extending into the arc chamber are the poles of a strong electromagnet, the coils of which are in series with the arc, so that their exciting current is the arc current.

In this manner, the strong magnetic field which exists between the poles of the magnets acts on the arc, and owing to such action combined with the influence of the voltage developed by the secondary 46—47 of the transformer, it happens that said action and influence being about equal in value, are each of them alternatively greater than the other, so that the voltage across the arc automatically rises and falls. Therefore, when the action of the magnetic

field is greater than the voltage produced by the secondary of the transformer, the current produced by said secondary has not enough pressure to pass across the arc and the condenser is charged, but an instant afterwards said action decreases in value, and the condenser discharges across same said arc. On the
5 other hand owing to the oscillatory nature of the circuit, which is arranged with proper values of capacity, inductance, and resistance, said charges and discharges of the condenser can be obtained several millions of times per second if desired, and in this manner a current of a great number of amperes can be secured through the oscillating circuit, even with a small amount of electricity
10 stored by said condenser. Just in the same manner as with a gallon of water could be produced a current of one thousand gallons per second through a pipe, if such pipe be connected with two different vessels, and said quantity of water could be forced through such pipe, by means of a piston adapted to one of said vessels, so as to transfer same said quantity of water from one to another vessel,
15 one thousand times per second. Obviously what can be easily performed with electricity, is not so feasible with the water.

Speaking in other terms, the small amount of electric power taken by the direct current motor 27—28, appears with a small loss on the alternator 42, and such power is delivered to the primary 44—45 of the transformer. Again, the
20 inductive action of this transformer produces on the secondary 46—47, a similar power still diminished in accordance with the efficiency of such apparatus, and finally the condenser is charged with a small amount of electricity in order to be converted into oscillatory energy. Obviously, if such electric power instead
25 of being stored by said condenser had been simply rectified, and directly applied to the charge of one of the above mentioned batteries, such power would only produce a very small effect on these accumulators, and the whole discharge of the other battery would never cause the complete charge of the second group. On the contrary, if same said power is stored by said condenser 48, and this
30 condenser is properly connected to an oscillatory circuit in which one of said batteries can be joined, and furthermore if by means of a rectifier the high frequency currents produced in such oscillatory circuit are forced to pass from the positive to the negative pole through said battery of accumulators, it is obvious to state that it is always possible to secure by these means, the number
35 of amperes required by said accumulators in order to get them charged in a given time. That is to say, with a small number of coulombs stored by the condenser 48, it is possible to produce on the oscillatory circuit a great number of amperes, if same said small number of coulombs are forced to pass and repass through said circuit, thousands or millions of times per second, just as was explained with the water analogy.

40 On the other hand, the values of the above named quantities: capacity, resistance, inductance and voltage can be varied in very wide limits, and therefore it is always possible to attain the required conditions in each case, in order to produce a given number of oscillations per second: The capacity of the condenser can be adjusted to a certain value by increasing or diminishing the
45 surface of its coatings. The resistance of the circuit can be adjusted to the required value by varying the length of the arc in the Poulsen lamp, or varying the number of lamps connected in series or parallel in the circuit. The inductance of said circuit can be varied by winding part of same circuit on an insulating frame, in such a manner as to obtain the number of turns required
50 to produce the desired inductance; and finally, the charging voltage can be regulated by increasing or diminishing the number of turns in the secondary of the transformer, or by varying the diameter of the wire employed in such coil. Finally in order to obtain a better efficiency from the alternator 42, it is convenient to use the resonance coil or adjustable inductive resistance 43,
55 in the circuit connecting said alternator with the primary 44—45 of the transformer. By so doing it is possible to adjust said resistance in order to obtain a state of resonance in the circuit, and in these conditions the current produced

by said alternator will be in phase with the impressed E. M. F.; therefore the effective watts will be a maximum in the primary and secondary circuits.

The adjustable resistance 29, which is disposed in the circuit connecting each battery of accumulators with the motor 27—28, is employed to adjust the current of the discharging battery to a fixed value, since it is important to obtain a constant number of revolutions from the alternator.

The commutator is furthermore provided with the voltmeters 56 and 57, and by means of the switches 58 and 59, the circuits connecting respectively both poles of each battery, can be closed through said meters, and the voltage of the discharging current may be so determined when desired. Finally, by means of the switch 60 connected across the terminals of the apparatus 40 and 41, such apparatus may be put on or out of operation at will.

With this arrangement, the initial charge of any of the above mentioned batteries, may be obtained by means of same motor 27—28, which in this case should be disconnected from the alternator 42, and coupled to any other motor, in order to be operated as a direct current generator. Such motor which is not illustrated in the drawing, may be a petrol or combustion engine of any kind, capable of an independent operation.

In such case, if it is desired to give a charge to any of the above mentioned batteries, the switch 60 should be closed, and next disconnecting the alternator 42, the direct current motor 27—28, should be coupled to the combustion engine, which once in operation will produce the running of said motor. This apparatus acting now as a generator will produce an electric current which passing through the terminal 27 will follow *via*: wire 26, terminals 18 and 17 of the commutator, (if it is the battery 1—2 which is going to be charged), wire 21, ammeter 22, pole 23, battery 1—2, path 9, switch 60, terminal 31, wire 30, resistance 29 and terminal 28. If on the contrary, it is battery 3—4 that should be charged, it is necessary to turn at first the cylinder 5 of the commutator by means of the handle 61, until the paths 11 and 12, come in contact with the brushes connecting the poles of the accumulators, in which case the conductive path 14, (Figure 2), will connect the contacts 18 and 20 of the ring encircling the cylinder. Under these conditions, the electric current produced by such generator will follow *via*: terminal 27, wire 26, terminals 18 and 20 of the commutator, ammeter 22, battery 3—4, path 11, terminal 39, switch 60, wire 30, resistance 29, and terminal 28.

In other words, each one of said batteries can be charged independently from the other, and once such result is attained, the combustion engine being already disconnected; if the plant should remain idle for some time, the cylinder 5 should again be turned until the brushes do not rest in touch with any of the above described conductive paths, and the whole arrangement will thus remain ready to be started at any instant.

Now it is easy to understand the whole operation of this mechanism. Suppose at first that the battery 1—2 has been charged, and that the cylinder 5, is brought to the position shown by the figure: such battery will immediately discharge through the following *via*: pole 23, ammeter 22, wire 21, contacts 17—18, wire 26, motor 27—28, resistance 29; wire 30; rotary transformers 40 and 41 (or through any other apparatus that may be used instead of such transformers in order to utilise part of the power produced by this discharge), pole 39, and path 9, through which the whole circuit is closed!

As a consequence of such discharge, the electric power thus developed will be expended by three different ways: a first part is wasted in overcoming the internal resistance of the several apparatus employed; and of the circuit connecting such apparatus; a second part is expended in the operation of the motor 27—28, and finally, the third part is expended in the operation of the apparatus connected to the poles 31—39 of the commutator, in order to produce a practical purpose independently of the operation of the plant.

It is well known how the mechanical power developed by the rotary motion

of the motor 27—28, can be turned into electrical energy by the alternator 42; and in the same manner it is well known how such electrical energy of low voltage can be transformed into one of high voltage by means of a transformer; and it is well known too how such high voltage electrical energy can be converted into oscillatory energy, and how the alternating currents produced by such oscillations, can be rectified in order to produce a direct current. However all such combination of apparatus and means, arranged to produce the charge of a battery of accumulators while another similar battery is discharging, was perfectly unknown before this invention, and a short consideration of the calculations involved in determining the different values of capacity, resistance, inductance, and voltage required by the several combined circuits of a small working plant of this kind, may be useful to give an idea of the procedure which in general practice can be followed.

Suppose that each one of the batteries 1—2 and 3—4 in said small plant, are obtained by the connection in series of 50 Edison accumulators.

Suppose that the voltage of each accumulator is equal to 1, 2 volts.

The voltage of each battery arranged with 50 accumulators connected in series will be equal to:

$$1.2 \text{ volts} \times 50 \text{ accumulators} = 60 \text{ volts.}$$

Suppose that the capacity of each accumulator is equal to 40 amperes-hours, The capacity of each battery, will be equal to: 40 amperes-hours.

Under such conditions if the battery 1—2 discharges at the rate of 40 amperes, such battery will be totally discharged in one hour, and the power thus developed during such time will be:

$$60 \text{ volts} \times 40 \text{ amperes} = 2400 \text{ watts.}$$

On the other hand, in order to obtain the complete charge of the battery 3—4 in one hour, it is necessary to provide during such time an electric current of at least 40 amps.

Suppose that in order to develop such current, it is desired to take from the power produced by the discharging battery, only a portion equal to:

$$40 \text{ amps} \times 10 \text{ volts} = 400 \text{ watts.}$$

With this object in view, the direct current motor should be arranged in order to take such current of 40 amperes, causing a drop of 10 volts on the line.

Suppose that the electrical efficiency of such motor is of 95 per cent; the above mentioned 400 watts will be reduced to:

$$\frac{400 \times 95}{100} = 380 \text{ watts.}$$

Suppose that the electrical efficiency of the alternator 42, is also equal to 95 per cent., the 380 watts delivered to said alternator, will be reduced to:

$$\frac{380 \times 95}{100} = 361 \text{ watts.}$$

Again such energy of 361 watts delivered to the primary of the transformer, will appear on the secondary of same apparatus, reduced in a certain amount depending on the efficiency of such transformer, which can be supposed equal to 89 per cent. Such energy will be thus reduced to:

$$\frac{361 \times 89}{100} = 321 \text{ watts.}$$

Which is finally the amount of electrical power delivered to the oscillating circuit, in order to develop the required 40 amperes of current.

Now suppose that the frequency of the alternator 42 is equal to 500. As it is well known, with an alternating generator, a high voltage is obtainable twice in each cycle. Therefore, if there are 500 cycles per second, we will obtain 1000 maximums of voltage per second; and as the condenser 48, discharges just at the time in which the maximum voltage is produced, it will

be obtained under such conditions 1000 discharges per second. Therefore, the quantity of electricity that must be stored by said condenser, can be determined by the following consideration: Suppose that the impedance of the oscillating circuit is equal to 15 ohms. As the current that should be maintained in said circuit must be equal to 40 amperes; the required voltage to develop such current will be equal to:

$$40 \text{ amps.} \times 15 \text{ ohms} = 600 \text{ volts.}$$

But in order to produce 600 volts by the discharge of the condenser, it is necessary to get it primarily charged to 1200 volts, since the average potential during the discharge is $\frac{V}{2}$ volts, in consequence:

$$\frac{V}{2} = 600, \quad V = 1200 \text{ volts.}$$

If the energy produced by the secondary of the transformer is assumed equal to 321 watts, and the voltage required for the charge of the condenser should be 1200 volts, the current delivered by said secondary will be equal to:

$$C = \frac{W}{V} = \frac{321}{1200} = 0.267 \text{ amps.}$$

On the other hand, as the frequency of the alternator has been admitted equal to 1000; in one thousandth of second, said secondary will deliver to the condenser: .000267 coulombs, or 267 microcoulombs:

Hence, the capacity of said condenser must be adjusted to store such quantity of electricity, and its value can be determined by the following formula:

$$Q = K \cdot V. \quad (3).$$

In which K, is the capacity of the condenser in microfarads, when Q is given in microcoulombs, and V is the maximum voltage.

Therefore, by transposition:

$$K_{mf} = \frac{Q}{V} = \frac{267}{1200} = 0.222 \text{ microfarads.} \quad (4).$$

On the other hand, it is well known that if it is desired to produce an oscillatory discharge through a circuit, the capacity, resistance and inductance of said circuit, must be arranged in such a manner, that the value given by the following equation:

$$2 \sqrt{\frac{1000 L_{mhs}}{K_{mfs}}} \quad (5)$$

be greater than the resistance of the circuit.

In which L, is the inductance of said circuit measured in millihenrys, and K the capacity of the condenser in microfarads.

It has been supposed that the resistance of the oscillatory circuit is equal to 15 ohms. Hence the above equation may be made equal to 20 ohms, and the value of L obtained from such formula, will satisfy the required conditions for the production of the oscillatory discharge in such circuit.

$$2 \sqrt{\frac{1000 L_{mhs}}{K_{mfs}}} = 20 \text{ ohms.} \quad (6)$$

and by transposition:

$$L_{mhs} = \frac{400 K_{mfs}}{4000}, \quad (7).$$

By substituting:

$$L_{mhs} = \frac{0.222}{10} = 0.0222 \text{ millihenrys,}$$

or equal to: 22200 centimetres.

Now it is possible to determine the number of oscillations per second that can be obtained in such circuit, whose value is given by the following formula:

$$N = \frac{5033000}{\sqrt{L_{cm} \times K_{mf}}}, \quad (8).$$

and substituting the already known values of the inductance and capacity, we obtain:

$$N = \frac{5033000}{\sqrt{22200 \times 0.222}} = 71900 \text{ oscillations}$$

per second, or 72 oscillations in each spark, since we have assumed that there are produced 1000 sparks per second.

The current strength developed by means of such oscillations can be determined by the following formula:

$$C = \frac{V}{\sqrt{R^2 + \left(6.28 \cdot N \cdot L - \frac{1}{6.28 \cdot N \cdot K}\right)^2}}, \quad (9).$$

Which gives the value of the current in terms of the impressed electromotive force (V), the ohmic resistance of the circuit (R), the inductance (L) in henrys, the capacity (K) in farads, frequency (N) in cycles per second, and the constant (6.28).

Hence by substituting in this equation we obtain:

$$C = \frac{600}{\sqrt{15^2 + \left(6.28 \times 71900 \times 0.0000222 - \frac{1}{6.28 \times 71900 \times 0.000000222}\right)^2}}$$

Now: $6.28 \times 71900 \times 0.0000222 = 10.$

and: $6.28 \times 71900 \times 0.000000222 = 0.1.$

and substituting:

$$C = \frac{600}{\sqrt{15^2 + \left(10 - \frac{1}{0.1}\right)^2}} = \frac{600}{15}, \text{ or}$$

$$C = 40 \text{ amperes.}$$

Which means that the impedance of the oscillating circuit is equal to the ohmic resistance of same circuit, since the inductive reactance and the capacity reactance are so combined, that the resultant value of the total reactance is equal to zero, and the only voltage required to produce the current of 40 amperes, is that to overcome the ohmic resistance of same said circuit, which has been admitted equal to 15 ohms. Which means also that the E. M. F. is in phase with the current, and therefore the watts are a maximum.

Hence there can be no doubt that the battery 3—4, will be fully charged while the other battery is discharging, inasmuch such effective current can be increased at will, even without taking more power from the discharging battery. In fact, it is easy to increase the number of turns of wire in the secondary 46—47 of the transformer in order to increase the voltage. Obviously as the amount of power delivered to the primary 44—45 of same apparatus is always equal to 321 watts, if the voltage is increased, the quantity of electricity that the condenser will receive will be accordingly reduced, as may be noted by the consideration of formula N.2. In consequence the capacity of same condenser must be accordingly diminished as may be seen from formula N. 4, and thus the number of oscillations per second will be also increased (equation N. 8). Finally by increasing the voltage, the current strength is proportionally increased, (formula N. 9).

Therefore, it is always possible to combine in the manner described the

values of the resistance, inductance, capacity and voltage in the oscillating circuit, so as to obtain the required current strength, to produce the charge of one of said batteries, while the other is discharging.

Once such result is attained, if the operation of the plant must be continued, it is necessary to reverse the connections of said batteries, and with this object in view, the cylinder 5 should be revolved until the conductive paths 11 and 12, come in contact with the brushes connected to the negative poles of said batteries; and then the battery 3—4 which is now fully charged, will be connected with the motor 27—28, and its discharge will be now produced through the following *via*: pole 25, ammeter 24, poles 20 and 18, wire 26, motor 27—28, resistance 29, wire 30, apparatus 40 and 41, and path 11, which is now closing this circuit with the negative pole of same said battery.

In other words the motor 27—28, the apparatus 40 and 41, and the alternator 42, will be still in operation just in the same condition described above, and in the same manner the high frequency currents are still developed, producing the same current strength which is now passing *via*: pole 50 of the condenser, arc-lamp 51—52, valve 34 of the rectifier, wire 32, contacts 19—17, wire 21, ammeter 22, pole 23, battery 1—2 (now connected with the pole 38 of the commutator through the path 12), wire 37, valve 36, inductance 55, and pole 49; or *via*: pole 49; valve 33, wire 32, contacts 19—17, wire 21, ammeter 22, pole 23, battery 1—2, path 12, pole 38, wire 37, valve 35, arc-lamp 52—51 and pole 50. In other words by the same series of the above enumerated phenomena, the battery 1—2 will be fully charged while the battery 3—4 is discharging.

It is obvious to state that the same procedure can be repeated indefinitely by the simple reversion of the connections of said batteries, from time to time, in accordance with the capacity of the accumulators employed, and the rate at which they are discharging.

In consequence, obtaining thus a continuous operation of such electric plant, its output can be easily determined, since from the power developed by the discharging battery, 400 watts only have been taken to produce the charge of the second group of accumulators, and the remnant of 2000 watts, that is to say a current of 40 amps \times 50 volts is still available on the circuit in order to be utilised particularly by the apparatus 40 and 41. In fact the loss of power caused by the internal resistance of one of said batteries and of the circuit connecting such apparatus is of very small value, and may be determined as follows:—

The resistance of each accumulator is only equal to: 0.005 ohms, and the resistance of the 50 accumulators connected in series will be:

$$0.005 \times 50 \text{ accumulators} = 0.250 \text{ ohms.}$$

The resistance of the circuit connecting said battery to the motor 27—28 and to the apparatus 40 and 41, is equally very small. Suppose that in such circuit are employed 20' of wire N. 5, (Braun & Sharp); the resistance of such wire is equal to 0.0003 per foot. In 20' its resistance will be equal to 0.006 ohms.

Hence the total resistance of battery and circuit will be equal to 0.256 ohms, and the loss of power caused by such resistance will be:

$$40^2 \text{ amps} \times 0.256 \text{ ohms} = 409 \text{ watts.}$$

And finally the effective output of such plant, would be:

$$2000 - 409 = 1591 \text{ watts-hours.}$$

Which are entirely utilised by the apparatus 40 and 41, and which can be employed at will, without impairing the normal running of the plant.

On the other hand, if it is desired to produce an automatic operation of such mechanism, the commutator 5, can be provided with the arrangement shown by the figure 1; in which two coils 62, 63, bent in the arc of a circle, are securely fastened to a wall 8 fixed to the base of same commutator. Said coils

are respectively connected by one of their ends to the positive poles 64, 65, of two different accumulators corresponding to each one of the above described batteries 1—2 and 3—4, and are furthermore provided with movable iron cores, which are equally bent to the same arc, and are fixed to a lever 66, mounted on the same shaft of the cylinder 5; and lately said cores and lever are properly

balanced to remain still in any position of the cylinder.
The automatic and alternative admittance of the electrical energy provided by said accumulators and required for the operation of these magnets, is obtained by means of an ordinary clock 67, fitted with contacts, so that the

minute and hour hand close the circuit when passing the contact strips.
In the arrangement depicted by this figure it is supposed that the commutator should be shifted every hour, and with this object in view, said clock 67 is provided with two strips 68, 69, arranged to make contact separately with the minute's hand once in every revolution. Nearer to the center of the clock's dial, are disposed twelve contacts 70 arranged to close the circuit through the hour's hand, which being shorter than the minute's hand, will never touch the above mentioned strips 68, 69; and thus when the clock is working, the circuit is obviously closed every hour through both hands. However in order to obtain the alternative operation of each one of the above described magnets; each one of the contacts 70 are alternatively fixed on two different metal discs 71, 72, shown apart from the apparatus by the Figures 3, and 4, and which properly insulated are disposed underneath the clock's dial. The metal disc 72 that is disposed above, is furthermore provided with six holes 73, affording passage to the corresponding contacts fixed on the other disc 71, which are larger than those of the former disc. Finally each one of said discs are respectively connected through the wires 74, 75, to the remaining ends of the coils described above, and the contact strips 68, 69, are respectively connected to the negative terminals 76, 77, of the accumulators, so that each one of said accumulators discharges every two hours through said coils, during the required time for the operation of the commutator. Obviously each time that the electric current is flowing through them, a magnetic force is exerted on the corresponding core which tends to draw it into the coil causing thus the revolution of the cylinder, until the connections of both batteries are reversed. By means of the handle 61, the cylinder 5 can be revolved independently from the operation of the clock, and the running of the whole plant may be thus stopped at any time, by moving and locating said cylinder in such a way as to break all the circuits.

Summarily the production of electrical energy by such procedure, can not be less inexpensive, since the operation of a plant of this kind does not require a continuous provision of fuel, neither the installation of a water-power plant which is not always obtainable. By such procedure, the installation can be made just in the place in which the electrical energy should be employed, and once the installation is made, the plant can be kept in operation indefinitely at a trifling cost of maintenance.

In fact, the batteries of accumulators which are the principal item in such procedure, can be obtained by the connection of the required number of cells or units, in accordance with the amount of power that should be developed. Obviously from the known accumulators the Edison type, being the most improved, is more suitable for such purpose. As it is well known in such type the active materials are oxides of nickel and iron, respectively for the positive and negative electrodes, the electrolyte being a 21 per cent. solution of caustic potash in water, which should be removed once every eight or nine months, and the only care required with such cells, is to maintain the tops of the plates well covered with solution. Obviously as such solution is continuously evaporating, the cells must be frequently filled with pure distilled water, but such operation is easily performed by means of the automatic refiller that the Edison Company provides with this object.

The rectifier employed in these installations, equally requires a trifling cost

of maintenance, since, if it is electrolytic, can be obtained by the connection of four cells, as shown in the figure, in which a neutral solution of ammonium phosphate may be employed. The electrodes of such cells being in the form of big plates are generally made of lead or polished steel, and aluminium for the anode and cathode respectively; since in such rectifiers it is made use of the well known property of the aluminium electrodes to let the electricity pass in one direction (when the aluminium electrode is cathode) but not in the other. Such electrodes if properly arranged have a very low depreciation and can be renewed at a trifling cost.

However, such rectifiers are only effective with low voltages (not more than 600 volts), so when the potential is greater it is necessary to join several cells in series divided into four groups connected to the oscillating circuit as shown in the figure, and generally it is preferable to employ any other type of rectifier, as for instance the mercury-vapor lamp which is of low cost, and its maintenance costs nothing.

If such rectifiers are employed, the inductance 55, may be used as auto transformer by connecting its terminal 13 to the terminal 52 of the arc lamp, and then both anodes of the vapor lamp should be connected respectively to each one of the terminals of said inductance, and its cathode must be joined to the terminal 19 of the commutator. Finally in order to close the rectifying circuit, the terminal 38 of same commutator must be connected to the sliding contact 78 of the above mentioned inductance. Under such conditions the voltage of the charging current can be regulated at will by means of said contact, which may be located in order to adjust the number of turns of wire that must be included in the secondary of same auto transformer, in accordance with the voltage that should be developed.

There are several other types of rectifiers that could equally be employed, but what has been told gives an idea of the manner in which such apparatus may be connected to the oscillatory circuits, in order to rectify the high frequency currents, and it does not matter the type employed, the cost of its operation and maintenance is always of trifling significance.

Finally the operation of such plant would require a particular attention in the apparatus used as spark-gap. If the arc-lamp is employed, the carbon electrodes should be frequently renewed, but this can be done equally at very low cost.

From the foregoing description taken in connection with the accompanying drawing, the advantages of this invention, will be readily apparent to those skilled in the art to which it appertains, and while I have described its principle of operation, together with the apparatus which I now consider to be the best embodiment thereof, I do not desire to limit myself to the arrangement of parts here shown, but aim in the appended claims to cover all the modifications which are within the scope of my invention.

Having now particularly described and ascertained the nature of my said invention, and in what manner the same is to be performed, I declare that what I claim is:—

IN A PROCESS FOR THE GENERATION OF ELECTRICAL ENERGY:

1. Disposed in combination: One or more batteries of electric accumulators already charged, and connected to produce a predetermined voltage; said battery or batteries of accumulators disposed to discharge through a circuit in which are connected the required apparatus for the utilisation of the greater part of the energy produced by such discharge; same said circuit furthermore provided with appropriate apparatus arranged to take the remnant of said energy, in order to be shunted into an oscillatory circuit; a second battery or batteries of accumulators connected to this oscillatory circuit, in order to be charged with the electric current developed by means of the oscillations obtained in such oscillatory circuit, while the first battery is discharging; a rectifier

disposed in such oscillatory circuit in order to direct said oscillations in such a manner that they follow from the positive to the negative pole through said battery; said oscillatory circuit furthermore provided with capacity, inductance and resistance of proper values to allow the development of the required current strength, that will produce the complete charge of said battery while the other is discharging; and finally means for reversing the connections of both batteries from one to another circuit, in order to obtain a continuous production of electrical energy; all substantially as herein described and for the purposes set forth.

2. Disposed in combination: One or more batteries of electric accumulators already charged, and connected to produce a predetermined voltage; said battery or batteries of accumulators disposed to discharge through a circuit in which are connected the required apparatus for the utilisation of the greater part of the energy produced by such discharge; same said circuit furthermore connected to a converter, or direct current motor coupled to an alternator, arranged to take the remnant of the energy produced by such discharge, in order to be shunted into an oscillatory circuit; a second battery or batteries of accumulators connected to this oscillatory circuit, in order to be charged with the electric current developed by means of the oscillations obtained in such oscillatory circuit, while the first battery is discharging. A rectifier disposed in such oscillatory circuit in order to direct said oscillations from the positive to the negative pole through said battery; said oscillatory circuit consisting of a condenser connected to the above named alternator, one or several spark-gaps or arc-lamps, and one inductance of proper value, to allow the production of an oscillatory discharge; a commutator conveniently arranged to reverse the connections of both batteries, from the discharging to the oscillatory circuit and *vice versa*, in order to obtain a continuous production of electrical energy; all substantially as herein described and for the purposes set forth.

3. Disposed in combination: One or more batteries of electric accumulators already charged, and connected to produce a predetermined voltage; said battery or batteries of accumulators, disposed to discharge through a circuit, in which are connected the required apparatus for the utilisation of the greater part of the energy produced by such discharge; same said circuit furthermore connected to a direct current motor coupled to an alternator, and arranged to take the remnant of the energy produced by such discharge; said alternator connected to the primary of a transformer, whose secondary discharges into a closed oscillatory circuit, consisting of a condenser, one or several spark-gaps or arc lamps, and one or several inductances of proper values to allow the production of an oscillatory discharge; a second battery or batteries of accumulators connected to this oscillatory circuit, in order to be charged with the electric current developed by the above mentioned oscillations, while the first battery is discharging; a rectifier disposed in such oscillatory circuit, in order to direct said oscillations from the positive to the negative pole through said batteries; a commutator conveniently arranged to reverse the connections of both batteries from the discharging to the oscillatory circuit and *vice versa*; in order to obtain a continuous production of electrical energy; all substantially as herein described and for the purposes set forth.

4. Disposed in combination: One or more batteries of electric accumulators already charged, and connected to produce a predetermined voltage; said battery or batteries of accumulators, disposed to discharge through a circuit, in which are connected the required apparatus for the utilisation of the greater part of the energy produced by such discharge; same said circuit furthermore connected, through one or more interrupters, with the primary of a transformer arranged to take the remnant of the energy produced by such discharge; the secondary of same transformer, connected to a closed oscillatory circuit, provided with capacity, inductance and resistance of proper values to allow the production of an oscillatory discharge; a second battery or batteries of accumulators connected to this oscillatory circuit, in order to be charged with the electric

current developed by the above mentioned oscillations, while the first battery is discharging; a rectifier disposed in such oscillatory circuit, in order to direct said oscillations from the positive to the negative pole through said battery; a commutator conveniently arranged to reverse the connections of both batteries from the discharging to the oscillatory circuit and *vice versa*, in order to obtain a continuous production of electrical energy; all substantially as herein described, and for the purposes set forth. 5

5. Disposed in combination, and for the purpose of connecting and reversing the operation of the two batteries of accumulators, which are employed in order to obtain a continuous production of electrical energy, the following: A commutator provided with several binding posts which may be connected to the corresponding poles of each one of said batteries; said posts provided with strips or brushes making a sliding contact with the surface of a cylinder mounted on a rotative shaft; said cylinder provided with properly insulated passages distributed on its surface, and arranged to connect the above mentioned strips, in such a manner that each one of said batteries can be alternatively connected to the discharging or to the oscillatory circuit; two electro-magnets fixed to the same apparatus, and provided with movable iron cores attached to a lever mounted on the same shaft of said cylinder, and so disposed, that when said electro-magnets are energised, the cylinder is forced to revolve alternately in opposite directions; each one of the coils of said electro-magnets respectively connected by one of their terminals, and through the minute and hour hand of an ordinary clock, to a source of electrical energy, and their other terminal directly connected to the remaining terminal of same said source; said clock provided with contacts conveniently insulated, and so disposed on its dial, that the circuit consisting of said magnets and source, can be closed through the minute and hour's hand alternately through each one of said magnets; Finally a handle fixed to the shaft of same said cylinder commutator, in order to obtain its operation independently of the running of the plant; all substantially as herein described and for the purposes set forth. 10 15 20 25 30

6. Disposed in combination in order to produce the alternative and periodical operation of a commutator: An ordinary clock provided with contacts connected to one of the poles of a source of electrical energy, and so disposed on its dial, that the minute's hand can engage periodically such contacts, when said clock is in operation; same said clock provided with other contacts, alternatively fixed on two different metal discs, conveniently insulated and disposed underneath the clock's dial; said contacts arranged to be engaged by the hour's hand, and said metal discs respectively connected to one of the terminals of two different electro-magnets, whose other terminal is connected with the remaining pole of the above mentioned source of electrical energy; said electro-magnets fixed to the same commutator and provided with movable iron cores attached to a lever which is mounted on the same shaft of the cylinder acting as commutator; Finally means for the operation of this commutator independently of the running of the clock. All substantially as herein described and for the purposes set forth. 35 40 45

7. Disposed in combination: Mechanisms or apparatus arranged, connected and operating substantially in the manner described, in connection with the appended drawing and for the purposes shown.

Dated the 13th day of March, 1918.

CARLOS BENITEZ. 50

[This Drawing is a reproduction of the Original on a reduced scale.]

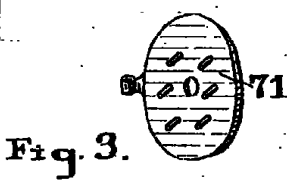
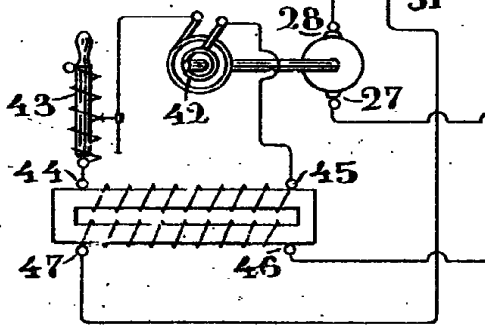
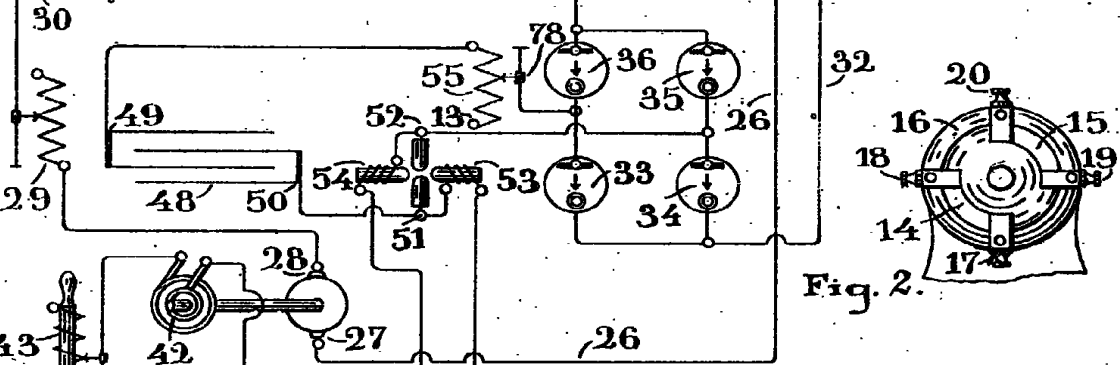
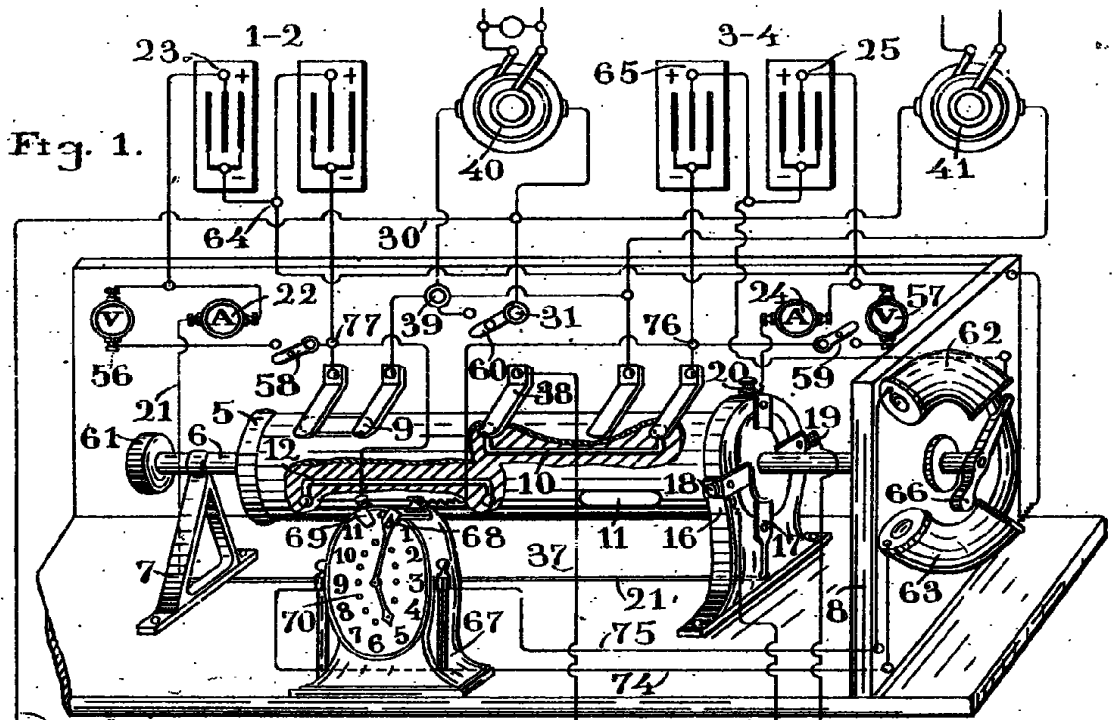

BIRMINGHAM
REFERENCE LIBRARY
PUBLIC LIBRARIES