

Levity's Labor Lost

by Robert A. Nelson

Several times during the 20th century, genius inventors discovered and developed a variety of elegant methods to nullify gravity. The energies and levitation phenomena they generated were of an unknown nature, but mainstream academia and industry have failed to follow through with duly diligent scientific debate and replication. For whatever reasons (e.g., death, war, secrecy), these wonderments faded into obscurity and were nearly lost until they became available on the internet. Here they are compiled for you to consider in context:

Edward Farrow : Condensing Dynamo

In the first decade of the 1900s, [Edward S Farrow](#) perfected a simple mechanical device which nullifies gravity. He demonstrated his so-called "Condensing Dynamo" at the 1926 World's Fair. Farrow never patented the invention, however, and today the only details that remain were published in *The Technical World Magazine* (November 1911), excerpted here:

"...Mr Farrow suspended a book from a pair of scales in his laboratory and weighed it. The volume tipped the scales at 18 ounces. To the book he attached a mechanical device in the shape of a small rectangular box, which he calls a 'condensing dynamo' and applied power from a neighboring electrical switch. A most remarkable thing then occurred. As the current set the wheels in the dynamo whirling, the indicator of the scales slowly receded until it stopped at 15 ounces. Apparently the book had lost 3 ounces of its weight -- in other words, one-sixth of the power of gravitation between the book and the earth had been overcome...

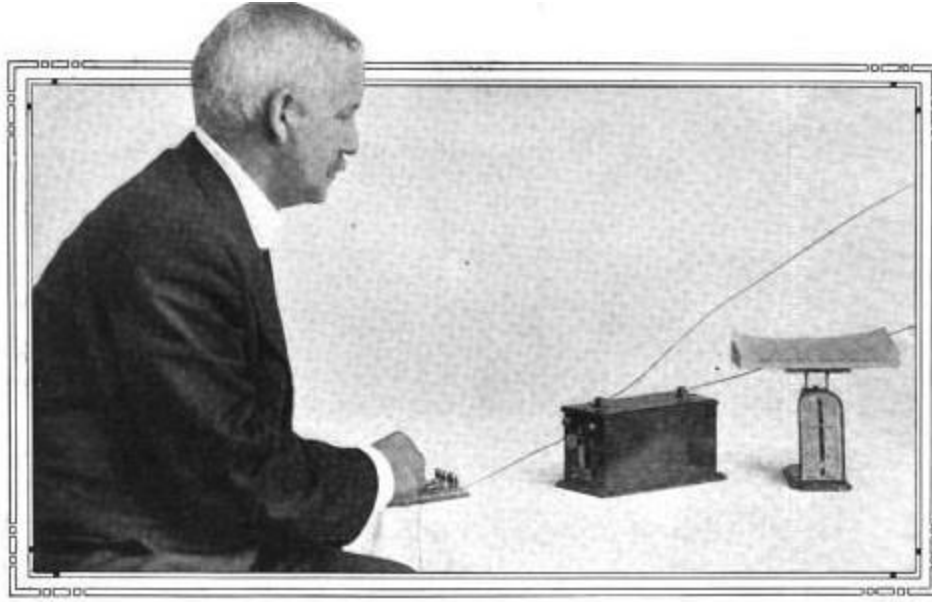

EDWARD S. FARROW AND HIS "CONDENSING DYNAMO."

"The invention is based on the intensification of Hertzian waves. it has been learned that by doing this a parallel and corresponding intensification occurs with the vertical force which controls gravitation. Thus buoyancy is added to an object held to earth or propelled towards it by gravity...

"It has been found that the mechanical devices for controlling electricity also apply to gravity, regulating or intensifying the force of this attraction of foreign objects to earth. By intensifying the motion of the electrical waves through the supposed ether there will develop components in all directions. If this force or motion acts vertically, it will by the law of reaction diminish a force such as gravitation acting downward toward the earth. For want of a better name, Mr Farrow calls this force, when acting upward, a "vertical component" and the name is well chosen...

"Mr Farrow's mechanical device increases the force of the Hertzian wave and this increased power is transmitted to the "vertical component". The latter thus intensified, offers a proportionate resistance to gravitation and the force of the latter is reduced, thus giving buoyancy to any object to which the condensing dynamo may be attached...

"[T]here is produced a horizontal, circular, flat sheet, so to speak, of Hertzian waves which radiate outwardly..."

Some investigators have speculated that the field was produced by a horizontal ring of spark gaps which generated a planar field that distributes the weight over a wide area of the gravitational field by its interaction with the geomagnetic field.

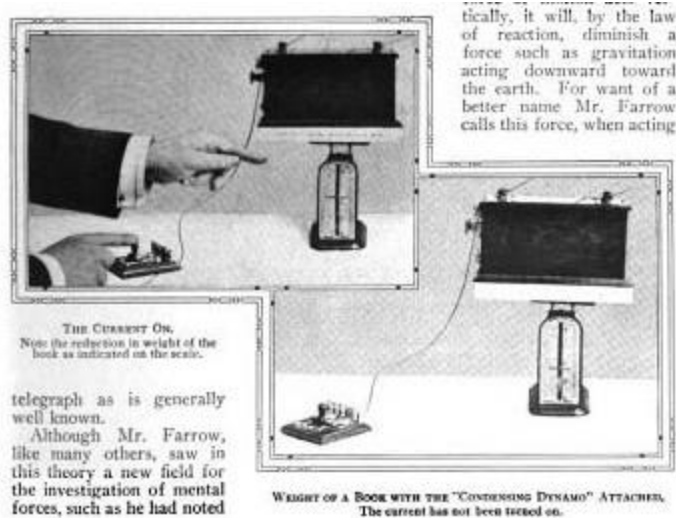

Luigi Rota : Aero Radio Ballistique

[Luigi G. V. Rota](#) (1886-1951) was an Italian scientist who worked with early radar technology until he discovered the Universal Current. His subsequent work was directed to development of instruments for the detection, collection, concentration, control and application of the current and its three telluric forms.

Luigi Rota



The Universal Current flows a few meters beneath the earth and generates a field in the atmosphere. Rota was convinced that all matter is composed of condensed Universal Current, and that any metal can be dissolved to slowly release that energy. He constructed laminated metal blocks which he buried to detect and collect the current for conversion to electricity. He also found that it affects gravity, and between 1910-1915, he developed a "Stabilisateur" that floated weightless.

"The device works by opposing the magnetic and electric field of the earth

rendering the device weightless", he said. After he made a public demonstration of the amazing machine, he was lauded in the French press as "Jules Verne in action".

Le Matin (15 September 1915)

(Havas.) ALBERT.

Du Jules Verne en action

MARSEILLE, 13 septembre. — *Du correspondant particulier du « Matin ».* — Actuellement réside dans notre ville un ingénieur italien qui aurait fait une stupéfiante découverte en résolvant le problème de l'immobilité absolue d'un corps dans l'espace.

Le professeur Louis Rota — c'est son nom, — aurait inventé un appareil qui, triomphant de la loi de la gravitation, pourrait se tenir immobile dans l'air à une hauteur de cinq cents, six cents, voire mille mètres, et serait susceptible de supporter un poids considérable.

On pourrait imprimer à cet appareil une vitesse prodigieuse dans n'importe quelle direction et l'arrêter à n'importe quel point. Tout cela, bien entendu, sans moteur mécanique d'aucune sorte, simplement par l'emploi des ondes hertziennes.

Le principe de cette invention reposerait sur une répartition spéciale des forces électriques et magnétiques, permettant d'obtenir des réactions de répulsion et d'attraction suffisantes pour maintenir l'appareil suspendu, immobile, à une hauteur variant de 400 à 1.000 mètres durant plusieurs heures, quarante au plus. En cas de vent ne dépassant pas quatorze mètres à la seconde, l'appareil reste au même point. En cas de vent plus fort, il se meut dans une direction verticale, monte au-dessus du courant aérien, et reprend son immobilité.

Des expériences ont été faites qui ont déjà donné des résultats. D'autres vont être faites à Marseille même, avec un appareil ayant la forme d'un cigare, long de 4 mètres, avec 75 centimètres de diamètre, et du poids de 95 kilos ; il peut enlever 45 kilos, rester 24 heures dans l'air, se déplacer jusqu'à 200 kilomètres de son point de départ. On pourrait le faire aller de Marseille à Paris (653 kilomètres en ligne directe) en trois heures, et de Paris à Turin (585 kilomètres) en deux heures quarante.

Rota considered the UC to be a fundamental energy, of which electromagnetism

was a byproduct. It is the source of all physical phenomena including life. The UC controls the manifestation of all matter, which is composed of UC and can be decomposed into it.

As described in his French Patent FR508472 ("Process and Apparatus to Maintain a Body in Suspension in the Air, Based on the Electric and Magnetic Forces"), the apparatus consisted of "a series of cylinders united by means of reciprocal transformers and connected to a battery, accumulator or dynamo so that each cylinder is connected to the opposite pole of the adjacent cylinder by coils having such an inductance as to prevent the wave circulating in the battery circuit.

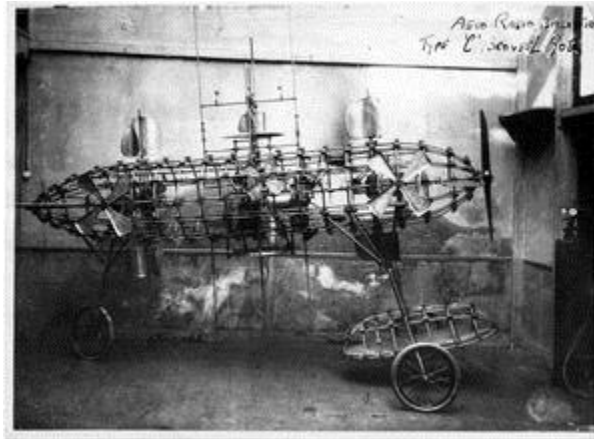

Rota describes a rotating cylinder element in his British Patent GB129059 ("Apparatus for detecting the proximity of mines, submarines, icebergs, &c."): "The cylinder has insulated windings connected through brush and ring contacts with a sensitive galvanometer, and may be rotated by a flexible shaft and bevel gear..."

French Patent FR508472 ("Process and Apparatus to Maintain a Body in Suspension in the Air...")

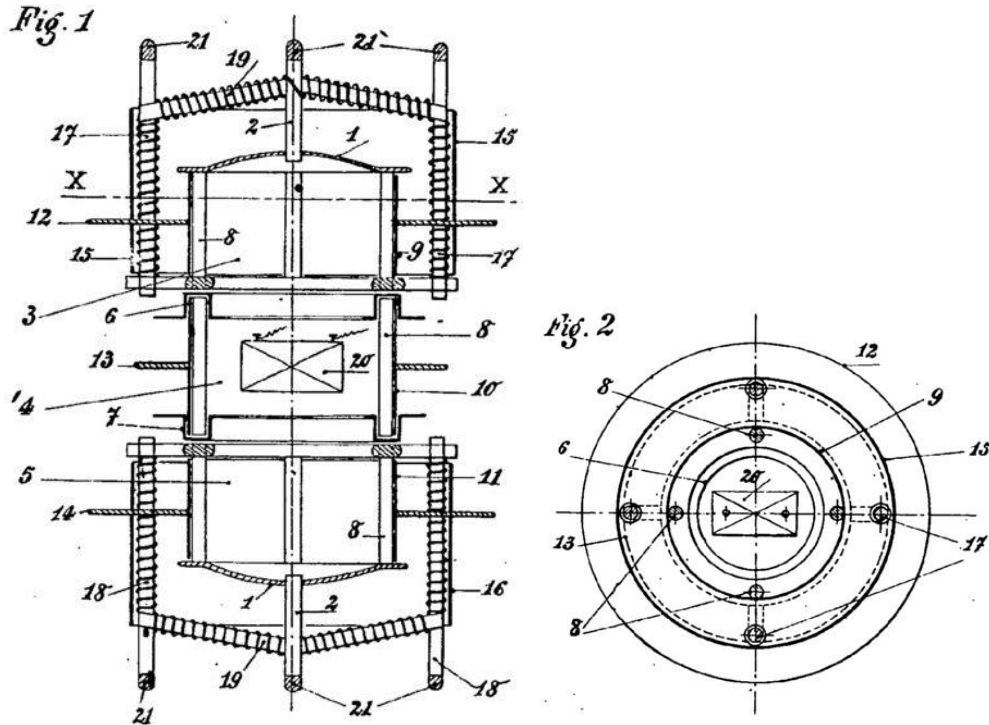

He described a rotating cylinder element again in his British Patent GB128624 ("Apparatus for the Concentration of Electric Waves in a Single Direction or upon a Fixed Point"), in which "the cylinders are made with parallel wires with an intermediate inductance."

In the 1970s [Dr. William Hooper](#) developed an "All-Electric Motional Field Generator" (US Patent US3656013) involving cylinders wound with parallel wires. The resultant field penetrates Faraday cages and modifies gravity. Perhaps the two inventions are related.

Henry Wallace : Kinemassic Force Field

In the 1970s Henry Wallace discovered the so-called Kinemassic Field (KF), which he generated by counter-rotating masses of half-integral spin nuclei material (copper, zinc, lead, tin, nickel, &c.). These are the same elements utilized by Louis Rota in his levitator, being used in the same way -- counter-rotating masses -- to neutralize gravity.

Wallace received three patents for his invention : US3626605 ("Generating a Secondary Gravitational Force Field"); US3626606 ("Generating a Dynamic Force Field"), and US3823570 ("Heat Pump").

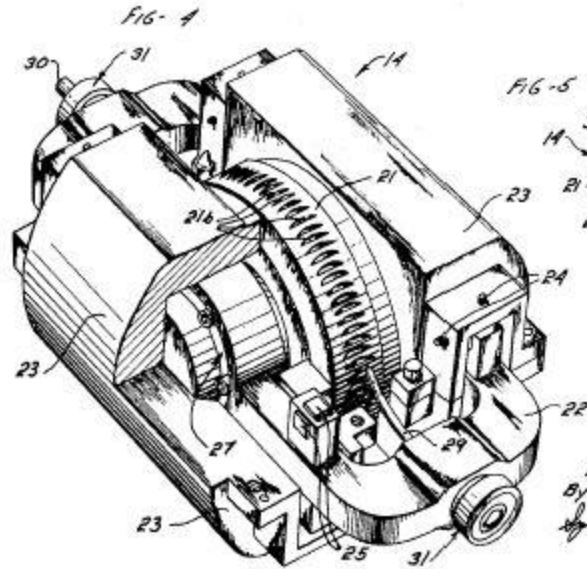

Therein he explained his discovery in terms of modern physics that might help us understand the phenomena produced by Rota.

"The kinemassic force field is generated as a result of the relative motion of bodies of elemental nuclei characterized by half integral "spin" values... The nucleons in turn comprise the elemental particles of the nucleus; i.e., the neutrons and protons... The value of the kinemassic force field... is the algebraic sum of the fields created by reason of the dynamic interaction of both elementary particles and of the discrete bodies... The kinemassic field causes the spin nuclei axes to reorient parallel with the axis of rotation and results in a field of summed dipole moments that form a secondary dynamic interaction with the surrounding materium.

"By spin nuclei material is meant materials in nature which exhibit a nuclear external angular momentum component. This includes both the intrinsic spin of the unpaired nucleon as well as that due to the orbital motion of these nucleons...

"The thus reoriented nuclear structure may lend itself to such uses as modification of the gravitational field acting on a body... generating of gravity waves for communication and other energy transfer.... in addition to utilization in many, many other fields..."

Bernays Johnson : Anti-Gravity Wave

Bernays Johnson also figured out this great mystery, but the secret was lost again after his death. A tiny article in Modern Mechanix magazine (January 1929) is all that remains to pique our curiosity:

RADIO WAVES KEEP AIRSHIP ALOFT

PROPELLERS and engines are not needed to fly the model airship of Bernays Johnson, who is shown with his craft in the photograph at the right. A powerful radio wave which neutralizes the pull of gravity is the force which keeps the ship aloft. Johnson experimented for ten years before he succeeded in discovering the principle of his anti-gravity waves. The ship can be controlled from within itself or from the ground. It was exhibited at the recent Boston radio exposition.



"Radio Waves Keep Airship Aloft -- Propellers and engines are not needed to fly the model airship of Bernays Johnson, who is shown with his craft at the right. A powerful radio wave which neutralizes the pull of gravity is the force which keeps the ship aloft. Johnson experimented for ten years before he succeeded in discovering the principle of his anti-gravity waves. The ship can be controlled from within itself or from the ground. It was exhibited at the recent Boston radio exposition."

Edgar Hollingshead : Odic Activity Ray

Another intriguing method of overcoming gravity was discovered and developed by [Dr Edgar Hollingshead](#) in the 1920s -- the Odic Ray, which also produced several other astounding phenomena such as disintegration and transparency.

This invention was never debunked as a hoax. It simply drifted in the ocean of information after the inventor died. Perhaps (probably), however, it has been developed in top secrecy. Fortunately for our inquiring minds, Dr. Hollingshead explained his discoveries at length in an article he wrote for the magazine *Radio Journal* (May 1923): "The Odic Ray -- It's Origin and Nature". It is quoted here at length lest any crucial factoids be edited out of existence:

"Some years ago I became convinced that matter did not depend upon physical properties for its weight, but upon the speed of the atoms making up the molecules, and I began searching for a process by which a force could be generated that would be high enough in point of speed to change the atomic speed of matter. Knowing that it would be impossible to release or generate such a force out of any form of matter, I turned my attention to the study of the nature of electricity and other natural forces.

"Believing that man could not conceive of a force unless there were something moving, I therefore believed that all forces must be made up of substance in motion. The substance that forms the natural "body" of forces of so-called laws of nature is not matter in the sense that the term is ordinarily used, but a substance so fine and vibrating at such a high rate of speed that it cannot be comprehended by any faculty of man excepting his reason. Thus considering the nature of electricity, reason tells us that we must have a substance traveling at a very high rate of speed, and that this substance must be governed and controlled by the same principles that govern all substance or matter. There must be one general principle governing the formation of substance throughout the universe. In other words, the substance or body of electricity, termed "amperage", must be made up of infinitely small eddies of force -- the same as ordinary matter is.

"As is well known, in matter we have three distinct classes of eddies of force, which seem to be a perfect counterpart of a solar system. We have, namely, the molecule, made up of electrons, also traveling in orbits; and the electron has been found to be made up of still smaller particles, also traveling in circular progression. Thus, we have three distinct phases of force in matter. We also have three distinct phases in action in the body or amperage of electricity. The world is more or less familiar with the positive and negative sides or phases of electricity, but I have proved by experimentation that there is a dominant or third phase in all forces. That is, there is a positive, a negative, and a dominant or solar manifestation, and these three phases of force are at definite distances apart in the point of speed, and their relationship is like 3, 6, and 9 on a rule. [*It is worth noting here that John Keely and Nikola Tesla both insisted on the importance of the 3:6:9 ratio.*]

"Considering electricity or any of the so-called natural forces of nature from this standpoint, we find that we have in reality two forces in one: -- we have a rectilinear action and also a rotating action in all forces. We can illustrate this action by considering a stream of water. Suppose we have a stream of water flowing at 20 miles per hour; the atoms making up the molecules of this water are traveling in circular progression at thousands of miles per second. This same condition I have proved to be existent in the nature of electricity, and I have also proved that these eddies of force making up the body or amperage of electricity can be broken up and the force corresponding to the electronic force in matter released. This force I have given the name of "Odic Activity", due to the principles involved in releasing or generating the same.

"I have found that the rate of speed of Odic Activity can be changed; its polarity reversed, and its direction of discharge controlled, as I have changed its rate all the way from where it would affect a photographic plate the same as ordinary light clear up to a point where it has disintegrated matter the instant it touched it. The only difference there can be between one ray and another is its difference in speed, plus a possible difference in polarity or character.

"Hence, it will be seen that since the polarity or character of the Odic Ray can be altered or changed, it is possible for it, when properly aligned, to duplicate any of the "rays" or rates of force known, between ordinary light and the point of disintegration of matter. This range or rates of force will encompass the X-Ray, the Radium rays, the Ultra-violet rays, and various rates that are known but which have not been named. [Got Terahertz?]

"As all matter is known to be formed of molecules, atoms and electrons, or of infinitely small particles of substance traveling at great speed in circular progression, reason proves to us that matter does not depend upon physical properties for its weight, but does depend upon the speed of these particles of substance, which sets up or causes a resistance to the flow of a force of nature passing into the earth. And as the predominating force that is known to be traveling into the earth is called "gravitation", the atomic speed or force stored up in these minute eddies of force must be resisting gravitation, -- thus causing what we call weight.

"With this hypothesis in mind, I found that by the use of the Odic Ray the degree or speed of these eddies could be altered, and this resistance changed, thus changing the weight of matter. In over a hundred different tests, I have changed the weight of practically all of the base metals, having changed aluminum approximately 20%. And to prove that the principle was correct, I have reversed the process and increased the weight back to normal, and to heavier than normal, thereby proving beyond a question of doubt that the weight of objects depends upon atomic force and not upon physical properties..."

[Popular Science](#) magazine featured a photograph of the Odic Ray Generator in March 1922:

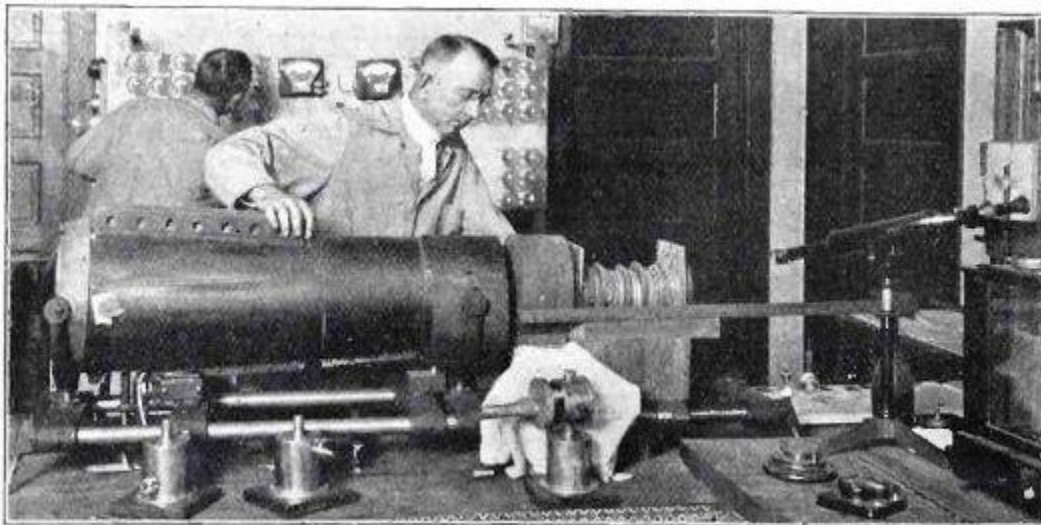

The accompanying caption read, "Discovery of "Odic Rays" of high penetration produced simply by the electric current drawn from an ordinary light socket, and

yet with the curative and medicinal value of X-rays, is claimed by Dr. Edgar L. Hollingshead, of Pasadena, Calif.

"With simple, inexpensive apparatus he is reported to have passed rays through 11-1/2 inches of lead and 4-1/2 inches of steel, at such strength as to sear dental X-ray films encased in tinfoil...

"Doctor Hollingshead's claims are based on tests made in the presence of eyewitnesses who selected at random the films exposed to the rays, retained the duplicates, and developed the two simultaneously in the presence of an unprejudiced committee. After exposure, these films were found to be perceptibly darkened.

"Doctor Hollingshead declares that... electricity is a substance. Amperage is the substance of electricity, and voltage is the speed. The form that material substances takes is due to their rates of atomic speed."

Hollingshead first intensified its atomic speed (voltage), then "broke it up to release the Od". The Odic Ray also caused hard clay to explode, and it made rocks transparent. Metal was caused to become "permanently cold beyond the possibility of ever becoming heated", and water instantly disintegrated into hydrogen and oxygen.

Dr Hollingshead elaborated further about the Odic Ray in an interview given to the Syracuse Journal (NJ) in January, 1922:

"Ten years ago I came to the conclusion that matter did not depend upon physical properties for its weight, but that weight is determined by the atomic speed of matter.

"It is accepted as fact that matter is an aggregation of molecules. Now, molecules are eddies of force, traveling in circular progression. These in turn are formed of still tinier particles similarly in motion, called atomic speed. Atoms are composed of electrons and ions, which have been split up and found to be composed of still smaller particles.

"I concluded, therefore, that there is no such thing as a solid, but that what we call a solid is in reality a seething mass of whirling force.

"The only way in which force can manifest itself is through resistance to other force, principally gravity -- which we call weight.

"Gravitation is force coming from the sun; the negative, levitation, is force returned from earth to sun. The weight of an object is the degree of resistance matter imposes in the path of these two forces, and the degree of resistance in turn is dependent upon the speed of the circular eddies of force of which matter is

composed.

"My experiments have been to find a way of generating force that would alter the speed of these whirls called matter so that I could change its degree of resistance to either gravitation or levitation and thus its weight...

"The Odic Activity Ray will affect a photographic plate or disintegrate matter, depending upon the wave length, which can be altered... It can be directed and focused... It has been generated to penetrate 16 inches of metal, and yet not harm the hand that encircles it.

"We have decreased the weight of aluminum, for instance, 20 per cent; then made it heavier than normal. And every base metal has responded to some degree, the change being instantaneous and permanent until again treated."

Dr Hollingshead received two Canadian patents for a dynamo: CA145749 ("Armature for Dynamos"); CA145750 ("Dynamo-Electric Machine"). No mention of the Odic Ray is made therein, but they might contain clues.

In 1931, Hollingshead self-published a booklet with the title, "Triune Brotherhood Project and Its Message To You : The Triune Brotherhood and How it Is Proposed to Use a Rediscovered Ancient Process Known as the Odic Ray To Establish a Great Movement for the Uplift of Mankind".

Today, circa 2017, Mankind, *et al.*, have moved on to tyranny instead.

Viktor Grebennikov : Cavity Structural Effect

[Viktor S. Grebennikov](#) (died 2001) was a Russian scientist, naturalist, and entomologist, well-known as the discoverer of Cavity Structural Effect (CSE). In the 1990s he designed and built an anti-gravitational platform based on bionic principles found in insect wings, and flew it at speeds up to 25 km/min.

Grebennikov made his discovery in 1981 while collecting insects for study at the Institute of Agricultural Chemistry:

"I was about to throw a piece of ethered cotton wool into the jar and then cap it, when a light little cocoon jumped up at me.

"It was oval-shaped, rather dense and non-transparent. One of the little "prisoners" in the jar must have pushed it. Cocoons can't jump on their own! But the cocoon proved me wrong. It jumped up one more time, hit the glass wall and fell down. I took it out and put it into a separate test tube. I looked at it through a binocular microscope at home and I have found nothing special about it. It was a

cocoon like any other, about 3 mm long and 1.5 mm wide. Its walls felt strong to the touch as they should. But the cocoon energetically jumped when lit or warmed by the sun but, it was quiet in the dark. It could jump 30mm lengthwise and, what I found even more remarkable, up to 50mm high. As far as I could tell, it flew smoothly, almost without tumbling. No doubt, the larva of the insect was responsible for the movement. But it was impossible to see how it did it.

"Jumping ahead, I can tell you that the cocoon finally produced a male insect of the Ichneumon family, the *Batiplestes anurus* species. It is beneficial for agriculture because its larvae parasitize the alfalfa weevil...

Grebennikov later found a stronger manifestation of the bio-gravitational effect in another insect, which he refused to identify:

"Why am I not disclosing the particulars of my discovery at this time? Firstly, because one needs time and energy for proving the truth. I have neither. I know how daunting is this task from my own bitter experience of trying to get recognition for my previous discoveries, including such an obvious one as the Cavity Structures Effect...

"The second reason for my "non-disclosure" is more objective. I have found these anti-gravitational structures only in one species of Siberian insects. I dare not even naming the class to which this insect belongs, because it seems to be on the verge of extinction and the population surge, which I had registered back then, was possibly local and final. Now, what would be the guarantee that dishonest people, half competent in biology, would not rush out to ravines, meadows and forests to catch perhaps the very last samples of this miracle of nature, if I were to name the genus and the species? What are the guarantees that they would not plough up hundreds of glades and cut down dozens of forests to get to this potentially lucrative prey? Therefore, let all I have related in this chapter and in the addendum remain science fiction. May nature herself never reveal this secret to them...

"I was examining the chitin shells of insects under my microscope in the summer of 1988 along with their pinnate antennae, the fish-scale microstructure of butterfly wings, iridescent colors, and other inventions of nature. I became interested in an amazingly rhythmical microstructure of one large insect detail. It was an extremely well-ordered composition, as though stamped out by factory equipment according to special blueprints and calculations. As I saw it, the intricate sponginess was clearly unnecessary either for the strength of the part, or for its decoration. I have never observed anything like this unusual micro-ornament either in nature, in technology, or in art. Because its structure is three-dimensional, I have been unable to capture it in a drawing so far, or a photograph. Why does an insect need it? Besides, other than in flight, this structure at the bottom of the wing case is always hidden from the eye. No one would ever see it properly. Was it perhaps the wave emitter using "my" multiple cavity structures

effect? That truly lucky summer, there were very many insects of this species and I would capture them at night. I was not able to observe these insects neither before, nor later.

"I placed the small, concave chitin plate on the microscope stage in order to again examine its strangely star-shaped cells under strong magnification. I again admired this masterpiece jewelwork of nature. I was about to place a second identical plate with the same unusual cell structure on its underside almost purposelessly on top of the first one. But then!

"The little plate came loose from my tweezers, hung suspended above the other plate on the microscope stage for a few seconds, then turned a few degrees clockwise and slid to the right, then turned counterclockwise and swung and only then it abruptly fell on the desk.

"You can imagine what I felt at that moment. When I came to my senses, I tied a few panels together with a wire and it wasn't an easy thing to do. I succeeded only when I positioned them vertically. What I got was a multi-layered chitin block and I placed it on the desk. Even a relatively large object, such as a thumbtack, would not fall on it. Something pushed it up and aside. When I attached the tack on top of the "block", I witnessed incredible, impossible things. The tack would disappear from sight for a few moments. That was when I have realized that this was no "beacon," but something entirely different...

"Look at these pictures. This is my rather simple device in assembly. A flexible cable inside the steering column transmits the movement from the left handle to the gravitational louvers. I lift off or land by joining or parting these "wing cases"...



The historical examples offered above seem to have applied a form of energy that remains unidentified though widely recognized. It appears to be a fundamental cosmic energy, and people have given it many names. Rota called it "Universal Current"; Hollingshead named it "Odic Rays". It is otherwise known as "Orgone" (Wilhelm Reich), "Prana", "Chi", "Ka", "Ether", etc. Whatever it is, the stuff plays no part in conventional science and technology, and the study of it is disdained as fringe, crackpot, and/or heretical. There has been no methodical, open source examination of the glaring question: What The Fornication?

It appears obvious that somehow during the 20th century we were cheated out of an amazing world of possibilities. Hopefully some brainiacs will figure this out in an open-source manner for the benefit of all mankind and the planet, rather than the unjust enrichment of a few million psychopaths, ultimately culminating in mass extinction. At present we have little idea of what we are missing, but if we

somehow survive ourselves for so long, perhaps some century soon we shall solve this problem and get on with the fundamental human business of conquering the Universe for fun and profit.

About the Author : Robert A. Nelson is a 10th grade dropout with no credentials. He established [Rex Research](#) in 1982 to archive hard-to-find information about suppressed, dormant and emerging technologies. He persists despite the seeming futility of the effort.
