

1,133,660.

A. PAPIN & D. BOUILLY.  
HELICOPTER.

APPLICATION FILED APR. 29, 1912.

Patented Mar. 30, 1915.

4 SHEETS—SHEET 1.

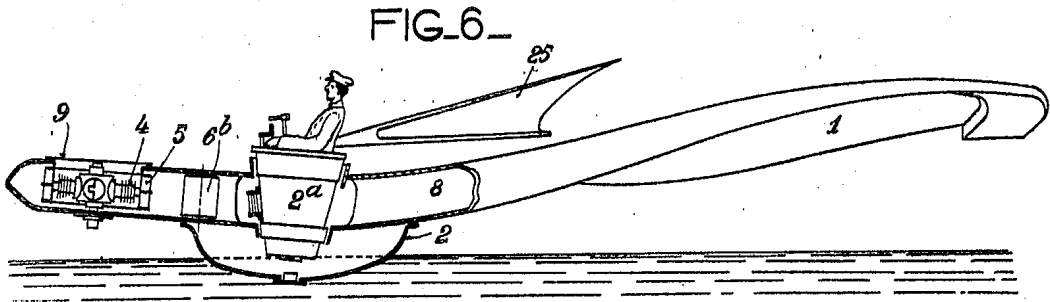
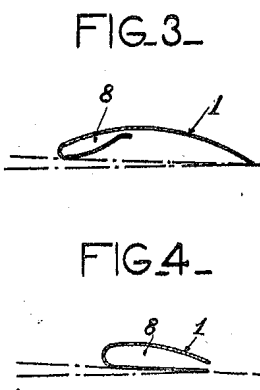
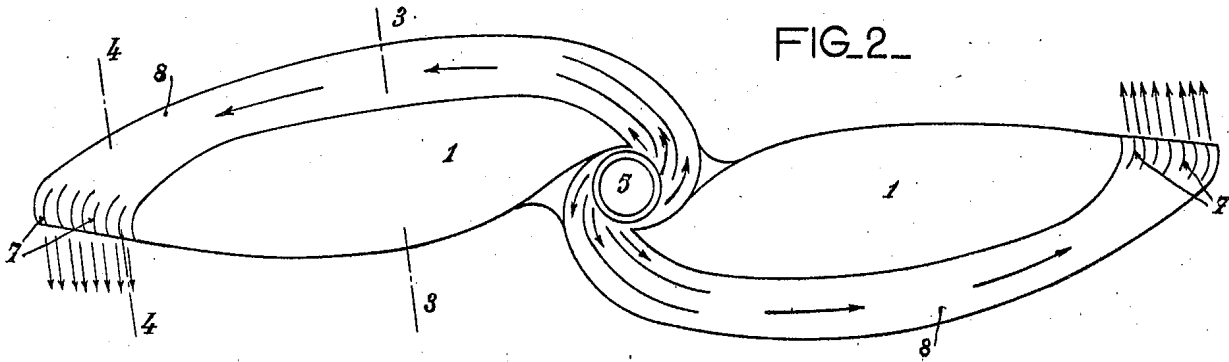
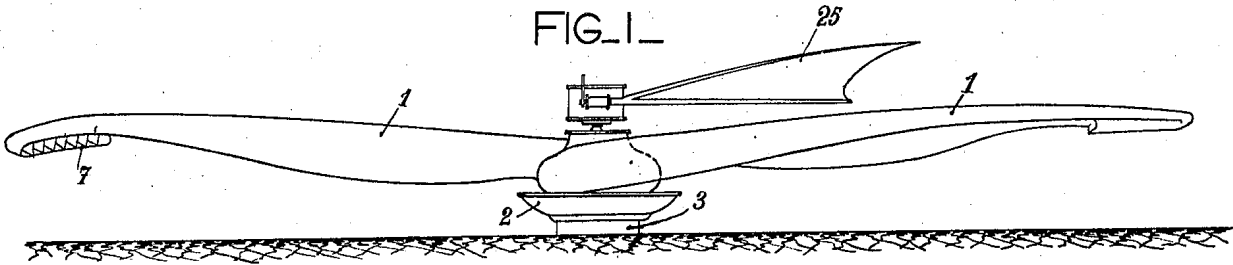

*Witness:*  
*Joseph F. Harsell*  
*John P. Harsell*

*Inventors*  
*Alexandre Papin*  
*Dimitri Bouilly*  
*by* *Attorneys*  
*Mar. Strong*

A. PAPIN & D. ROUILLY.  
 HELICOPTER.  
 APPLICATION FILED APR. 29, 1912.

1,133,660.

Patented Mar. 30, 1915.  
 4 SHEETS—SHEET 2.

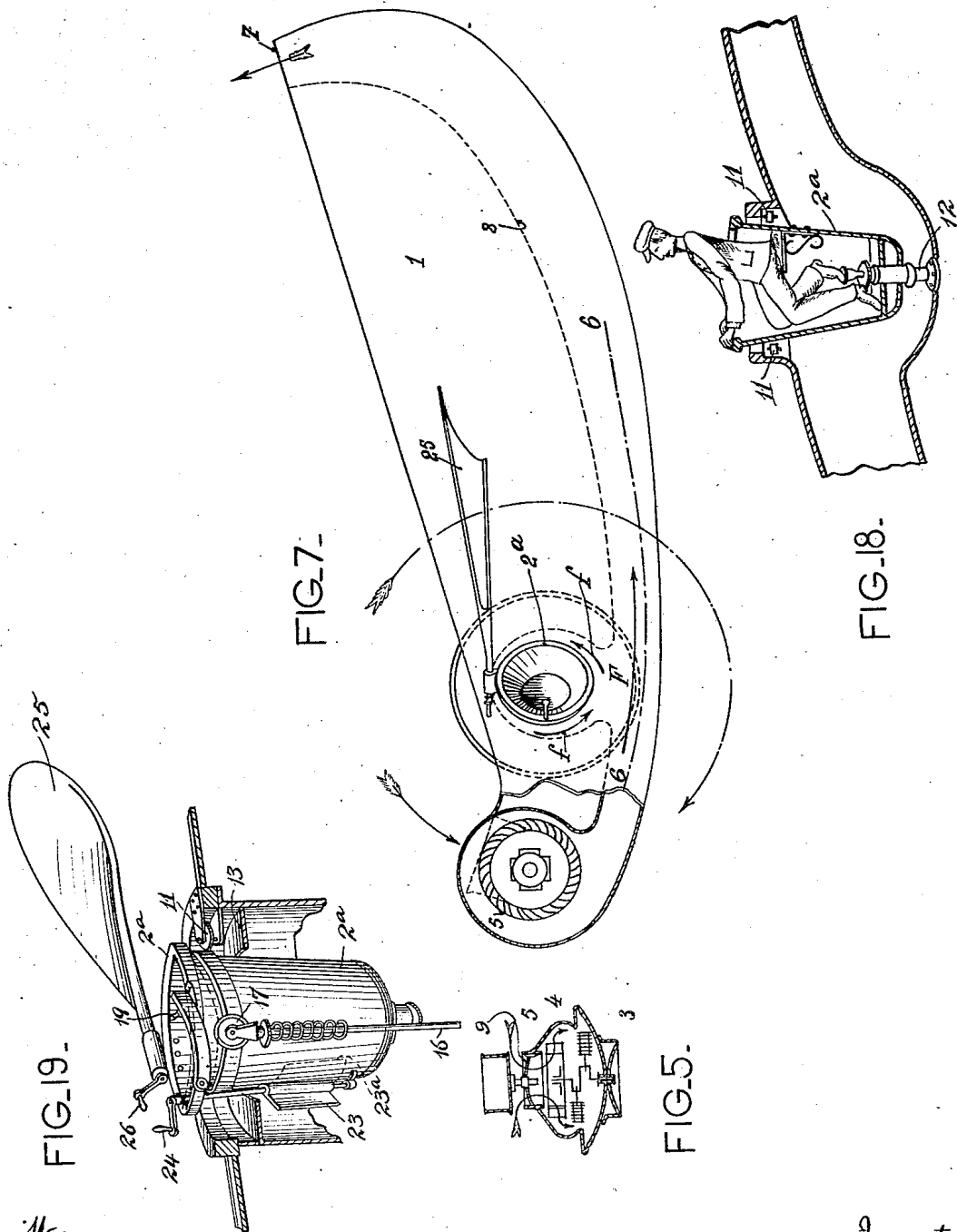

Witnesses:  
*Clara Frank*  
*Jules Jelenka*

Inventors  
 Alphonse Papin  
 Didier Rouilly  
 by *Attorneys*  
 their Attorney

A. PAPIN & D. ROUILLY.  
 HELICOPTER.  
 APPLICATION FILED APR. 29, 1912.

Patented Mar. 30, 1915.

4 SHEETS—SHEET 3.

1,133,660.

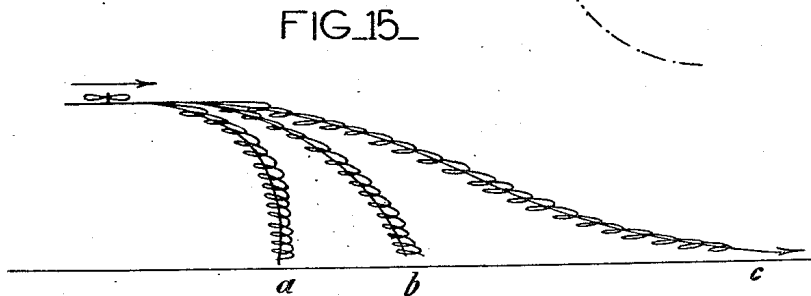
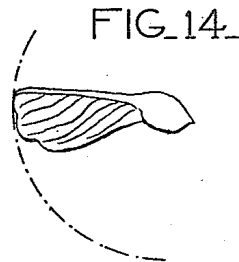
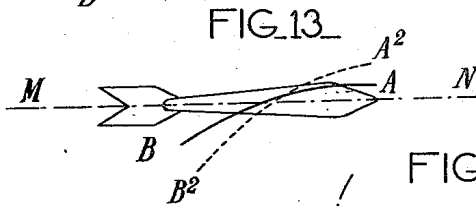
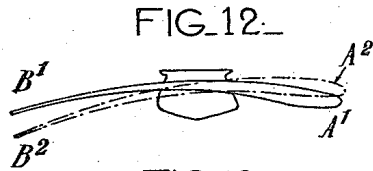
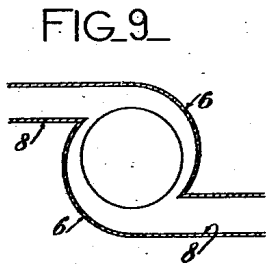
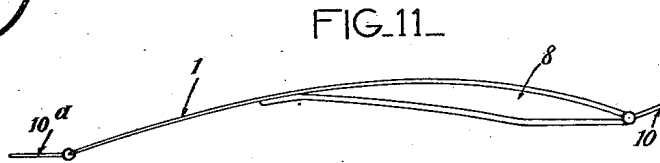
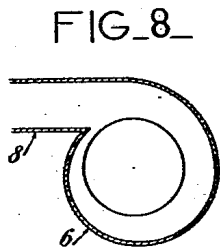

Witnesses:  
*Charles L. ...*  
*Julie ...*

Inventors  
 Alphonse Papin  
 Didier Rouilly  
 by *Otto ...*  
 their Attorney

A. PAPIN & D. ROUILLY,  
 HELICOPTER.  
 APPLICATION FILED APR. 29, 1912.

Patented Mar. 30, 1915.  
 4 SHEETS—SHEET 4.

1,133,660.

FIG. 16\_

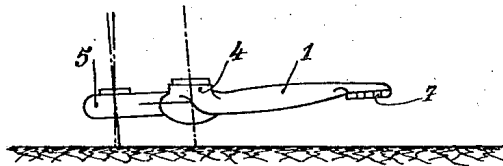

FIG. 17\_

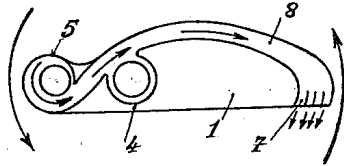
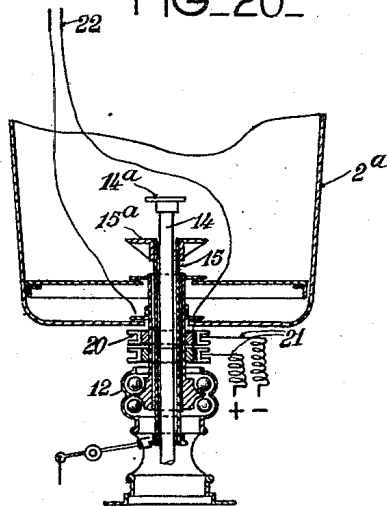

FIG. 20\_



Witnesses:  
*Clara L. French*  
*Julie Zelenka*

Inventors  
*Alphonse Papin*  
*Didier Rouilly*  
 by *Chas. M. ...*  
 their attorneys

# UNITED STATES PATENT OFFICE.

ALPHONSE PAPIN AND DIDIER ROUILLY, OF PARIS, FRANCE.

## HELICOPTER.

1,133,660.

Specification of Letters Patent.

Patented Mar. 30, 1915.

Application filed April 29, 1912. Serial No. 693,776.

To all whom it may concern:

Be it known that we, ALPHONSE PAPIN and DIDIER ROUILLY, citizens of the Republic of France, residing at 9 Rue Condorcet, Paris, in the Republic of France, have invented new and useful Improvements in Helicopters, of which the following is a specification.

This invention relates to helicopters and has for object improvements therein, particularly defined hereinafter and applicable to all helicopter machines traveling through a fluid, such as aeroplanes, hydroplanes, submarines, aerial or submarine torpedoes, weapons of projection of all kinds, parachutes, and others.

The invention consists substantially in an improved helicopter in which the propulsion is effected by the reaction obtained from jets of air blown into the atmosphere through passage orifices or nozzles in the helicopter, on the principle of the æolipile.

The improved helicopter has a single propeller or screw provided with one or more hollow blades or wings, at the ends of which the orifices of issue are located, the said screw carrying blower means adapted to impel air through the passages and orifices of the wings, and its boss adapted to act as support for the helicopter when it is resting on the water or the ground.

Another feature of the improved helicopter in its adaptation to flying machines, consists in the provision on the screw blades or wings of steering planes at front and back resembling those of an ordinary aeroplane, and means whereby the steering surfaces can be intermittently actuated from the car when the blade is passing through any desired meridian.

The pilot car is independently pivoted over the boss of the screw on a vertical spindle passing through the center of rotation and all the control gear is mounted on the car.

In the accompanying drawings, which are by way of example only, Figure 1 is an elevation of an improved helicopter according to this invention. Fig. 2 is a horizontal section of the same, Figs. 3 and 4 are transverse sections at the lines 3—3 and 4—4 of Fig. 2. Fig. 5 illustrates a prime mover with fixed cylinders, which can be adopted in the machine. Fig. 6 is a vertical section at the line 6—6 of Fig. 7 of a machine with a single bladed propeller and rotary cylin-

der engine. Fig. 7 is a plan view of the same machine with parts broken away. Figs. 8 and 9 are diagrammatic views of two types of fan casing. Fig. 10 is a diagrammatic view of a propeller blade or wing. Figs. 11 or 12 are views of a wing. Fig. 13 is a sketch of a flying machine mentioned in the description. Fig. 14 is a sketch of a sycamore leaf for showing certain conditions of equilibrium of the machine. Fig. 15 is a diagram descriptive of the parachute descent of the machine. Figs. 16 and 17 are an elevation and sectional plan respectively of a helicopter according to the invention. Figs. 18, 19, and 20 illustrate constructional details of the car.

The helicopter comprises in its essentials a motor fan group of any type capable of drawing in atmospheric air through an inlet duct which although not necessarily directed forward relatively to the direction of motion, is at least arranged so that the wind resulting from the motion does not resist the intake of air referred to. This air drawn into the fan casing or envelop, is forced through passages in the blades or wings of the propeller, the outlets or nozzles of which passages are arranged in directions approximately tangential to the circumferences described by the various points of the wings. In this manner the wings undergo a reaction due to the destruction of equilibrium resulting from the absence of a part of the wall of the inclosing passages or ducts into which the air was forced, this reaction being applied somewhere on the surfaces opposite the orifice and in the extension of the axis of the latter. This unbalanced pressure creates a thrust which is used to insure the rotation of the propeller, the operation being similar to that of the æolipile, hydraulic reaction wheel, and other like devices.

The propeller 1 has any number of blades or wings four, three, two (as in Fig. 1) and even one only, as in Fig. 6. The propeller may even have a large number of wings or blades so as to constitute a wheel.

For reasons of equilibrium, the motor fan group is placed at the center when the number of wings is two or more, that is when the propeller has an axis of symmetry. On the other hand in the case of a single bladed propeller, or a propeller having two unequal blades, the motor is shifted to the end away from the single blade or main blade, so as to

constitute a counterweight, for reasons hereinafter referred to, leaving at the center of gyration the only possible place for the pilot and his car. In such a case it will be noticed  
 5 that the center of gyration is located very close to the center of gravity (it would coincide with it if the form of the wing did not interfere to give rise to a certain longitudinal thrust) so that the addition of a cup  
 10 shaped member 2 fitting closely on the under part of the propeller about its axis of gyration, enables the said propeller to rest in equilibrium on water or on the ground, the said cup member 2 owing to its volume,  
 15 water-tight fitting, and progressively rounded form, operating as keel or as base plate while continuing to take part in the rotation of the propeller. For certain purposes however such as trials in a fixed position, trans-  
 20 port, etc., or for rising from or landing on certain nature's of ground, a detachable support 3 may be added to the cup member 2 and centered on the axis of the same in such manner as to allow rotation of the propeller  
 25 when this support rests on the ground on skids, wheels, anchors, dampers, and the like.

The motor fan group in this case operated by gas or a combustible vapor, is supplied  
 30 with fuel and lubricating oil from tanks arranged near the center of gyration in such manner that centrifugal force will tend to supply the same to the motor in greater amount when the speed is greater and the  
 35 engine consequently consuming more petrol and oil.

The engine proper 4 (Figs. 5 and 6) may be a turbine or cylinder engine, and if the latter the cylinders may be fixed or rotary.  
 40 In the first case the fan wheel 5 is simply mounted on an extension of the engine shaft (Fig. 5.) In the second case the fan wheel may with advantage constitute part of the engine itself the latter forming a sort of  
 45 boss for the ring or fan blades distributed around the periphery (Fig. 6). In both cases the fan is inclosed in a casing or envelop 6 which may have one delivery passage 8 (Fig. 8) two delivery passages (Fig.  
 50 9) or more according as the fan has to supply one, two or more propeller blades or wings. In each delivery passage there may be provided a register 6<sup>b</sup> Fig. 6 for the regulation of the air pressure. This fan casing  
 55 is of light material and is connected to the light skeleton of the wings by strong fastening means capable of resisting the considerable centrifugal stresses developed when the machine is working, and imparting in addition great rigidity to the wings in spite of  
 60 their lightness. The air forced by the fan into the passages 8 finds its way to the atmosphere through the orifices 7 suitably arranged and directed in the wings.

65 The engine exhaust is admitted to the fan

casing and the passages 8 in the wings, whereby the air forced through these passages by the fan is heated, the heat radiation from the engine assisting in this operation, and the engine at the same time cooled. 70  
 In this manner a portion of the heat which would otherwise be lost is usefully applied in doing work of expansion, thereby increasing the total thermal efficiency of the helicopter. 75

When a petrol vapor blowing device is used to compress the air, the general arrangement may be the same whether the blowing device replaces the engine 5 or is auxiliary thereto. In both cases the blowing device or devices arranged in the framework of the wings would continue to draw in atmospheric air and force it through the same orifices. The number of orifices 7 or groups thereof is proportional to the number of wings and arranged as near as possible to their ends so as to receive a high lineal speed, this being a condition for good efficiency. 80  
 85

The air delivery passages 8 formed between the walls constituting the front portion of the wing are of such section that the external form of the propeller wings satisfies the conditions of yielding a good lift and small resistance to advance (Fig. 10). The sections of Figs. 3 and 4 conform to this principle. With regard to Fig. 4, to appreciate the effect of a section of this form moving through the air it should not be lost sight of that the end element (duct outlet) is in reality extended by a fluid stream of great length, capable of completely changing the apparent ratio of height to length. 90  
 95  
 100

The inlet 9 of the fan, or the intake of the blowing device, is always directed upward from the machine, so that the cup shaped member is tight fitting, and in order to avoid any indraw of water, twigs, grass, stones, dust or the like when the machine is resting on water or the ground. Provision is also made for small quantities of water in the form of spray to be entrained by the air in its passage through the orifices, thus enabling at a given instant small quantities of water in finely divided form to be introduced to effect an energetic cooling of the engine. 105  
 110  
 115

The rounded form of the cup shaped member is such that rotational motion continued for several instants when the said member is on the ground will not give rise to shock owing to irregularities of the ground. In the same way the form of the wings, the flexibility of their rear edge and the small angle of contact which the wings make with the ground or water, avoid all risk of shock or fouling. 120  
 125

The cup shaped member is of suitable curvature enabling it to roll on other points than its center and consequently to travel 130

over the ground under a very small general inclination and also to traverse to an extent sufficient to counteract landing oscillations in a wind, a certain trajectory analogous to that of a spinning top or a cask bottom considered as extremes in opposite senses.

Figs. 16 and 17 illustrate diagrammatically a helicopter with the fan directed inversely with respect to the wing, the engine shaft being inclined to the vertical. The object of this arrangement is to introduce a gyroscopic action acting in suitable direction to give a lift to the engine side and thus keep the flying machine as nearly as possible in the horizontal.

It is known that the effect of an inclination of the propeller axis to the vertical is to produce a tendency to advance in the direction of this inclination. That is to say a sustaining screw having its axis vertical becomes also a propulsive screw when its axis ceases to be exactly vertical. To steer therefore it is only necessary to incline the axis in the proper direction, and to produce inclination of the axis it is only necessary to exert on the wings by suitable warping, reactions capable of giving the required couple. According as the inclinations required are to take place in the plane of the trajectory or in a plane perpendicular to this trajectory, the actuations referred to should be made at different points of the circle swept through by the wing, or in other words at different meridians, which will be determined by the pilot who has to face in a direction which is that of his own trajectory. This is equivalent to saying that the pilot will have to raise or lower as required the point of a wing at the exact instant it passes to his right, to his left, behind him, in front of him, or in any meridian which he may determine. To raise or lower a wing or part thereof it is necessary to be able to instantaneously change its inclination. Admitting therefore that this action can be exerted on the wing at any point in its circular travel, the problem of steering is solved and with it all the variations of this problem such as oblique flight vertically or laterally, turns, loops inclined or straight positions, etc.

To communicate to the wings of the screw a variable inclination in the case firstly of a screw having several wings rigidly fixed on their boss, that is of which the general inclination is permanently fixed, it should be observed that each wing, which constitutes an actual aeroplane rotationally mounted, will steer itself also by the same means. Thus a wing 1 constructed as shown in Fig. 11 of thin wood of thickness of about 3 to 5 mm. and provided with front rudder 10 and back rudder 10<sup>a</sup>, would tend under the action of these rudders directed as shown in the figure to give the whole

owing to the elasticity of the wing, the general direction A<sup>2</sup> B<sup>2</sup> instead of the initial direction A<sup>1</sup> B<sup>1</sup> (Fig. 12) the boss of the propeller then behaving like the fuselage of an aeroplane constrained to follow a fixed trajectory M N while its wings acted upon by some maneuver, would pass from the similar position A B to another position A<sup>2</sup> B<sup>2</sup>, Fig. 13, becoming warped relatively to their line of fixation. Such a deformation of the order of 10° at most at the present instance, is merely a matter of elasticity or assuming the natural flexibility of a wing constructed as described, a simple question of equilibrium between five acting forces, which are: (1) centrifugal force, depending on the speed; (2) the lifting effort, limited by the weight and in consequence practically constant; (3) the internal pressure due to the air compressed in the passages in the wing; (4) the gyroscopic action of the rotating masses, depending on the speed; (5) the reactions of the steering planes, the directions and magnitudes of which can be varied at will. The problem can thus be solved in every case. The rear steering plane can be located in the current of air from the orifices, so that it may have the maximum effect.

In the case of a screw with a single wing there is another even more simple solution. In this case there is no longer present, as before, the resistance of two opposing wings mounted on the same boss, but only the moment of the center of gravity about the center of gyration, to which is added a certain gyroscopic force tending to keep the axis of the boss parallel to itself, both these forces being however sufficiently weak not to offer serious resistance to the control, considering that these forces can be determined in the design. For this particular state of equilibrium it results that the maximum inclination of 10° will be obtained in this case by an adjustment of the boss itself to the horizontal, which adjustment will be minimized by slight deformations of the wings due to their elasticity and not totally eliminated although existing to a lesser extent in the present case. It is sufficient therefore in this case in order to solve the problem, to allow for the whole machine, *i. e.* for its boss and the pilot car supported thereby, a roll of total amplitude less than 10°, say 8°. This oscillation of 8° owing to the suitable inclination of the wing when designing, is distributed between an oscillation of 4° to the left and an oscillation of 4° to the right, the deviation of the axis of the car from the vertical being limited to this amount. This deviation is impressed only on the car and not on the pilot, who will be able to compensate the disturbances more easily than a horseman, swimmer, or mariner, can compensate the disturbing

forces of considerably greater magnitude, frequency and irregularity to which they are subjected. In all types of the machine the same control of the inclination of the wings will serve to insure a parachute descent if the engine fails (Fig. 15).

It will be observed that if a screw of inclination nearly zero and suitably weighted, is allowed to fall rotating on itself at a slow speed, whereby owing to the combination of the velocities of horizontal rotation and vertical progression, the wing although horizontally directed, encounters the surrounding air at a certain angle. As long as gravity, supplying the necessary driving power, maintains the necessary rotation, the device will continue to work during the whole time of its fall like a true helicopter. A natural example of this kind of retarded descent is furnished by the seed leaf of various trees, in particular of the sycamore (Fig. 14).

The same control which allows the obtaining of the greatest possible inclination, say  $10^\circ$ , will also allow, when necessary, the smallest inclination, say  $0^\circ$ , and this even if the driving power of the machine completely fails. For this reason all the control apparatus both in machines having a plurality of wings and in those with one only, have the feature of setting themselves to this zero inclination as soon as the driving power fails. The arrangement adopted for this purpose is the following. The rudders or steering planes are actuated by means of air compressed or rarefied by means in the helicopter, through the agency of such devices as elastic diaphragms, bellows, pistons, deformable tubes on the principle of the pressure gage tube, and others. The setting to zero is provided for when no fluid is circulating, by opposing springs which restore these rudders to a determined and fixed position. On the other hand the movement of the rudders can take place only when fluid is circulating and is effected by means of a system of cocks or valves controlled from the car by means hereinafter described.

There will now be described the means used to incline the wing or wings in the manner just referred to, either in the duration of several revolutions of the screw, or during a fraction of a revolution at the proper instant. The car  $2^a$  is mounted at the center of gyration on a spindle so as to be capable of turning independently of the general rotation of the screw itself. Figs. 18 to 20 show one method of this mounting of the car. In these figures the car  $2^a$  is deeply lodged in the boss of the propeller with a view to lowering its center of gravity, and is kept in position near the top by a series of rollers 11 (at least three) and near the bottom by a ball bearing treadle 12. A

suitable clearance is allowed between these parts to render impossible an accidental binding in the case of slight deformations. A packing ring 13 is provided between the car and the body of the screw, so as to reduce air leakage through the gaps, such leakage being further opposed by the fact that the air in this zone is kept in agitation, thereby lowering its static pressure. Fig. 7 illustrates the method by which a whirling motion is created in this zone, as indicated by the small arrows  $f$ , under the effect of the main circulation denoted by the arrows  $F$ . By this means an induced current of low static pressure is obtained.

The treadle bearing 12 (Fig. 20) is itself hollow to provide for the passage of several concentric rods 14, 15, normally held raised by spiral springs, not shown, and terminating at the top in separate circular pedals  $14^a$ ,  $15^a$ , by pressing on which with the foot the lowering can be controlled in spite of the relative rotation of the car. One of these rods acts directly on a distributing element such as valve, piston, or the like of the engine. The other transmits its action through a lever to another distributing device controlling the supply of the fluid for actuating the rudders hereinbefore referred to. The other similar rods 16 provided with rollers 17 (Fig. 19) are guided by the body of the machine externally to the car and terminate near the edge of the same, as shown in the figures. These rods are controlled by the raising or lowering of a hinged portion  $2^b$  of the edge of the car, the under edge of which portion is cut in the form of an inclined plane. This hinged portion is manually actuated by handle 19. The purpose of this control gear is to come into use as required during a fraction of the revolution only, and consequently will admit compressed or rarefied air to the wing-inclining mechanism at the exact instant this wing passes through a determined meridian, and only at this instant, and to renew this intermittent action during several consecutive rotations, if desired.

In spite of the necessity of pivoting the car in the screw in such manner that it remains fixed while the screw revolves, or at least so that the car only turns when it is required and this at as slow a rate as desirable, it will be seen that as many devices as are required are provided to regulate or actuate during flight all the mechanisms associated with the screw, with as much facility as if the entire machine were fixed. To complete these controls, collecting rings 20 are arranged rotating in contact with fixed brushes 21 to enable the pilot to control the ignition current of the engine by means of a switch 22 arranged in the car.

It has been already said that by actuation of rudders carried by the front and rear



edges of the screw wing it is possible to obtain not only general inclination of the plane of the screw for the purpose of deviation from the line of travel, either vertically or laterally, but also intermittent inclinations of the wings in one meridian with the view of obtaining other useful complex motions, especially at starting and at landing. There has also been described the mechanism whereby this control can be effected. There remains only to be described the means adopted for keeping the car relatively fixed, in default of which the control of the parts 2<sup>b</sup> for example, will be impossible, not to speak of the inconvenience which would result from such an undesirable rotation.

It should be noted firstly that if the operation of the various controls accidentally should break down, the pilot would still be able by changing his position inside the car, to shift the center of gravity of the whole machine and consequently to convert a slow vertical descent (a) (see Fig. 15) into a slow inclined descent such as (b) or (c) for the purpose of choosing a suitable landing place.

According to the phases or circumstances of the flight there are three distinct movements for maintaining the fixity of the car.

*First means.*—It was seen that the car is immersed in an induced circular current of air derived from the main or driving circulation. The car is provided with a vane 23 (Fig. 19) pivoted on a rod in such a manner that it can project radially from the car or lie flat along the wall of the same by suitable actuation of a control handle 24. The circular air current thus exerts an entraining action on the car, which is stronger the more the surface 23 projects radially from the car. Since the friction between the car and the body of the helicopter at the treadle and rollers gives rise to a tendency to motion in the opposite direction, it will be easy to obtain a suitable balance between the two opposing forces, whereby the car may be kept in a constant direction or allowed to turn as slowly as desired in one or the other direction. It should be noticed that the force on the vane 23 will not fail even in case of stoppage of the engine, since the screw will continue to rotate in the same direction, and owing to centrifugal force will maintain during the descent a powerful current of air from the center toward the circumference.

*Second means.*—Another surface 25 is arranged so as to constitute a rear empennage which offers sufficient resistance to the wind caused by the flight when a certain speed has been attained, to allow the first means to be dispensed with. When landing head to wind this surface will act so as to automatically direct the pilot to face the air currents,

which he can resist by inclining the machine against the same.

*Third means.*—This is obtained by the rotation of the above surface 25 about its longitudinal axis of a handle 26. This surface is influenced by the general current developed by the screw, a current which is descending or ascending according as the screw rotates owing to the drive of the engine when the machine is rising, or owing to the action of gravity when the machine is descending freely. When the machine is flying horizontally, this effect combines with that of the wind caused by flight, the result being that the direction of the surface 25 giving equilibrium changes from one case to the other.

In the different helicopters illustrated and described by way of example the cooling of the engine is effected by means of the driving circulation. To increase the effect the air is heated only after having passed through the fan, *i. e.* if the general arrangement is not well suited to such direct cooling the point of dissipation of which can be shifted if required by introducing into the delivery passage a radiator specially provided for this purpose. The heat of the exhaust is also used to effect expansion of the air, and to this end the burnt gases from the engine are broken up into a large number of small jets by means of a perforated plate, so as to avoid any projection of flame.

The invention is obviously not limited to the particular machines and detail arrangements described, these having been selected as examples only. The machines described are aerial helicopters adapted to carry one or more persons, but without exceeding the scope of the invention these machines can be modified to provide helicopters capable of various uses and applicable in a general fashion to any machine for traveling through a fluid, such as various aerial and nautical locomotion devices, aeroplanes, hydroplanes, submarines, aerial and submarine torpedoes, weapons of projection, parachutes, and others.

Having now described our invention, what we claim as new and desire to secure by Letters Patent is:

1. In a helicopter, the combination of a hollow rotating screw propeller, having conduits therein which open into the atmosphere through nozzles arranged at the ends of the screw propeller wings, substantially in a tangential direction to the circle described by said nozzles, a fan carried by the screw propeller and adapted to suck in air from the atmosphere and impel the same through the conduits and nozzles, a motor carried by the screw propeller and adapted to drive the fan and a car rotatably mounted on the screw propeller, substantially as described and for the purpose set forth.

2. In a helicopter, the combination of a single hollow rotation propeller wing having a conduit therein which opens into the atmosphere through nozzles arranged at the end of the wing substantially in a tangential direction to the circle described by said nozzles, a car around which the wing is adapted to rotate and blower means adapted to suck in air from the atmosphere and impel the same through the conduit and nozzles, said blower means being carried on the wing on the end of the wing remote from the nozzle carrying end, substantially as described and for the purpose set forth.

3. In a helicopter, the combination of hollow rotating propeller wings having conduits therein which open into the atmosphere through nozzles arranged at the end of the wings substantially in a tangential direction to the circle described by said nozzles, a car around which the wings are adapted to rotate, blower means carried by the rotating propeller wings and adapted to suck in air from the atmosphere and impel the same through the conduits and nozzles, the propeller wings having a central boss beneath the car, which is adapted to act as a support for the helicopter when it is resting on water or on the ground, substantially as described and for the purpose set forth.

4. In a helicopter the combination of hollow rotating propeller wings having conduits therein which open into the atmosphere through nozzles arranged at the end of the wings substantially in a tangential direction to the circle described by said nozzles, a car around which the wings are adapted to rotate, blower means adapted to suck in air from the atmosphere and impel the same through the conduits and nozzles and a register located in said conduits for the regulation of the air pressure, substan-

tially as described and for the purpose set forth.

5. In a helicopter the combination of hollow rotating propeller wings having conduits therein which open into the atmosphere through nozzles arranged at the end of the wings substantially in a tangential direction to the circle described by said nozzles, a car around which the wings are adapted to rotate, blower means adapted to suck in air from the atmosphere and impel the same through the conduits and nozzles the motive part of said blower means including a gas or internal combustion engine and means for leading the exhaust gases of the engine into the air conduits for heating the air, substantially as described and for the purpose set forth.

6. In a helicopter the combination of hollow rotating propeller wings having conduits therein which open into the atmosphere through nozzles arranged at the end of the wings substantially in a tangential direction to the circle described by said nozzles, a car around which the wings are adapted to rotate, blower means adapted to suck in air from the atmosphere and impel the same through the conduits and nozzles, means for creating an induced current of air around the car, and a vane pivoted on the car and projecting into said air current, substantially as described and for the purpose set forth.

In testimony whereof we have signed our names to this specification in the presence of two subscribing witnesses.

ALPHONSE PAPIN.  
DIDIER ROUILLY.

Witnesses:

LOUIS MOSES,  
H. C. COXE.