

May 31, 1932.

P. N. NISSEN

1,861,062

ROOF FOR PORTABLE BUILDINGS

Filed July 8, 1929

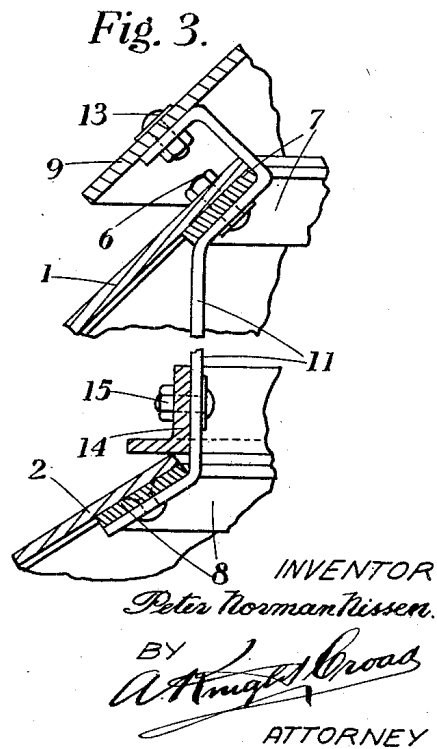
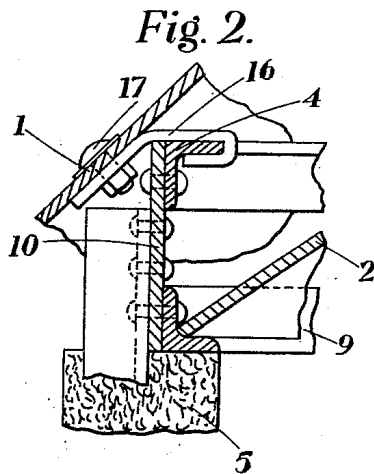
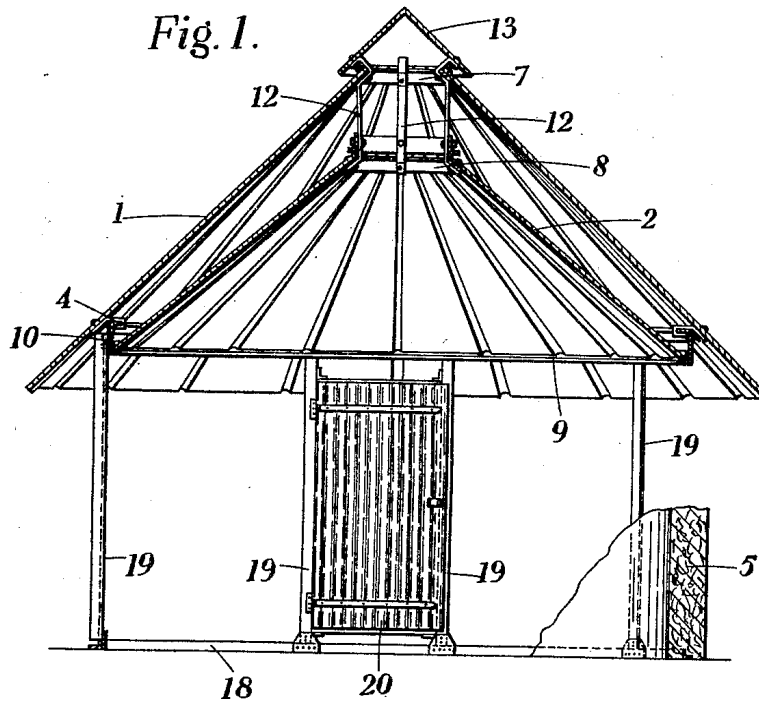

UNITED STATES PATENT OFFICE

PETER NORMAN NISSEN, OF HODDESDON, ENGLAND

ROOF FOR PORTABLE BUILDINGS

Application filed July 8, 1929, Serial No. 376,720, and in Great Britain July 10, 1928.

This invention relates to the roofs of portable buildings and is a modification and simplification of the roof structure described in the specification to British Patent No. 129,777 and it has for its object a construction of conical roof for use with circular buildings such, for instance, as the mud huts used by the natives of tropical countries, which huts are at the present time roofed with various vegetable material which not only harbours vermin and is consequently eminently unsanitary but has a very transitory life.

According to the present invention the roof comprises a main roof ring of substantially the diameter of the wall of the building, a secondary ring of equal diameter to, spaced apart from and disposed below said main roof ring, a central support comprising two superimposed cone-shaped rings spaced at a suitable distance apart by stays or uprights, a plurality of sheets adapted to be grouped and arranged to form a ceiling, the upper ends of said sheets being supported on and fixed to the lower of the coned rings forming part of the central support, their lower ends being supported on the secondary ring, and a plurality of sheets adapted to be grouped and arranged to form the roof, the upper ends of said sheets being supported on and fixed to the upper of the coned rings forming part of the central support, their lower ends being supported by and fixed to the main roof ring.

In the accompanying drawings which illustrate this invention:—

Figure 1 is a view of a hut fitted with the improved roof which is shown partly in section.

Figure 2 is a broken view in section on an enlarged scale showing the method of positioning the lower ends of the roofing and ceiling sheets, and

Figure 3 is a similar view showing the attachment of the roofing and ceiling sheets and the cap or cowl to the central support.

Throughout the views similar parts are marked with like numerals of reference.

The roof consists of a roof proper 1 and a ceiling 2 each of which is made up of a plu-

ality of sheets of triangular form. At the edges of these sheets which may be of any suitable metal or other suitable material is a single corrugation 3 so that when the adjacent sheets are in place and overlap the corrugations form an interlock. The outer or lower ends of the roofing sheets are supported by and fixed to a ring 4, the lengths of said sheets being such as will allow of a substantial overhang from the wall 5 of the hut, said ring being preferably formed in a plurality of sections for convenience in packing and storage. The upper ends of the roofing sheets are supported by and fixed by bolts 6 (Figure 3) to a cone-shaped ring 6 which forms the upper part of a central support. The upper ends of the ceiling sheets 2 are supported by and fixed to a cone-shaped ring 8 which forms the lower end of the central support. The lower ends of the ceiling sheets are supported on a secondary ring 9 spaced apart from the ring 4 by means of distance pieces 10.

The upper and lower rings 7 and 8 of the central support are spaced at a suitable distance apart as to provide the desired cavity between the ceiling and the roof and are positioned by means of a plurality of vertically disposed metal stays 11.

The apex of the roof is covered in by a cowl 12 and in order to provide an air outlet said cowl may be supported on the upper ends of the stays 11 which for this purpose are continued beyond the ring 7 and bent over outwardly as shown in Figure 3, the cowl being secured to said strips by the bolts 13.

The upper ends of the ceiling sheets 2 are preferably secured in position by an L-shaped ring 14 placed around the stays 11 to which it is secured by bolts 15, but if desired said ceiling sheets may be secured to the ring 8 by bolts or the like.

The lower ends of the roofing sheets are secured to the main roof ring 4 by means of clips 16 which are adapted to engage the horizontal rib of said ring and are secured to the sheets by means of bolts or the like 17 as shown in Figure 2.

The roofs forming the subject of this invention are chiefly intended to be used in con-

- junction with a wall of adobe or the like, and to facilitate the erection of the roof a second main ring 18 connected to the rings 4 and 9 by vertically arranged bars 19 may be employed so as to form a skeleton framework for the roof which enables it to be built and put in position before the adobe wall is made or before it has dried sufficiently to support the weight of the roof. Two of these bars form suitable posts for the door 20.
- By using a complete door, and by covering the aperture at the base of the central support with fine wire gauze, the building may be made mosquito proof.
- The internal diameter of the central support must be such as will provide ample room for a man to stand within it, in order to enable the roofing and ceiling sheets to be secured to their respective supporting rings.
- What I claim is:—
1. In a roof for circular buildings the combination of a skeleton framework comprising a plurality of vertically arranged bars, a ring secured to the lower ends of said bars, a second ring secured to the upper ends of said bars, a supplementary ring secured to said bars a short distance below the last named ring, a central support comprising two cone-shaped rings arranged one above the other, means for spacing said rings at a suitable distance apart comprising a plurality of vertically disposed stays, a plurality of sheets of triangular form adapted to be grouped and arranged to form a ceiling the upper ends of said sheets being supported on the lower of the cone-shaped rings forming the central support, means comprising a clamping ring for securing said sheets to the central support, their lower ends resting on the supplementary ring, a plurality of sheets of triangular form adapted to be grouped and arranged to form a roof the upper ends of said sheets being supported on and fixed to the upper of the cone-shaped rings forming the central support, their lower ends being supported by and fixed to the second named ring.
 2. In a roof for circular buildings the combination of a skeleton framework comprising a plurality of vertically arranged bars, a ring secured to the lower ends of said bars, a second ring secured to the upper ends of said bars, a supplementary ring secured to said bars a short distance below the last named ring, a central support comprising two cone-shaped rings arranged one above the other, means for spacing said rings at a suitable distance apart, a plurality of sheets adapted to be grouped and arranged to form a ceiling the upper ends of said sheets being supported on the lower of the cone-shaped rings forming the central support, means for securing said sheets to the central support, their lower ends resting on the supplementary ring, a plurality of sheets adapted to be grouped and arranged to form a roof the upper ends of said sheets being supported on and fixed to the upper of the cone-shaped rings forming the central support, their lower ends being supported by and fixed to the second named ring.
- PETER NORMAN NISSEN.