

PAPER • OPEN ACCESS

Design and analysis of a radiant charger using 5 coils and 5 poles of neodymium magnet as a rotor drive

To cite this article: M N Hidayat *et al* 2019 *J. Phys.: Conf. Ser.* **1402** 033100

View the [article online](#) for updates and enhancements.

You may also like

- [How, where, and when to charge electric vehicles – net-zero energy system implications and policy recommendations](#)
Sandro Luh, Ramachandran Kannan, Russell McKenna et al.
- [Daemonic quantum battery charged by thermalization](#)
Matias Araya Satriani and Felipe Barra
- [Data-driven insights into South Korea's national utilization of the EV charging infrastructure](#)
David Woo and Yeong Jae Kim

Design and analysis of a radiant charger using 5 coils and 5 poles of neodymium magnet as a rotor drive

M N Hidayat, R Santoso*, I N Syamsiana, A Setiawan and S Djulihenanto

Electrical Engineering Department, State Polytechnic of Malang. Jl. Soekarno-Hatta No 9, Malang 65141, Indonesia.

*rahmad_santoso@polinema.ac.id

Abstract. A radiant charger is a free energy device that can be applied to produce electricity. The term free energy means that this equipment does not use fuel, such as fossil fuel to produce energy. This research aims to design and analyze a prototype of a radiant charger using five coils and five neodymium permanent magnets. In this research, a primary battery is needed as a source to generate mechanical work to rotate the rotor, a coil and a transistor is also needed to charge a secondary battery before the primary battery runs out. The results of the design and testing of the device produces a rotor rotation of 1020 rpm at 346 volts.

1. Introduction

The need for energy is increasing in accordance with the times. This causes the energy crisis that occurs in the world supported by the depletion of fossil fuels. A lot of research is done to find alternative fuels to replace fossil fuels. There have been many studies conducted by researchers to solve these problems by utilizing existing natural potentials, such as the use of sunlight, wind, ocean currents, microbes, etc., as a source of energy power generation [1]. With the natural potential, it is expected that the cost of consumption to meet energy needs can be reduced [2].

A radiant charger is a free energy device that can be applied to produce electricity. The term free energy means that this equipment does not use fuel, such as fossil fuel to produce energy. In designing a radiant charger, there are several things that must be considered, namely the number of coils and permanent magnets. Coil is a device that functions as an electromagnetic to drive the rotor. In a radiant charger, the coils have two functions, i.e. (i) as an electromagnetic source when the electrical current is flowing through it, and (ii) as a current source when the electrical current does not flow into the coil. This research is focused on knowing the effect of the number of coils and permanent magnets used with respect to the rotation speed of the rotor and the voltage generated.

2. Bedini SSG

One of the biggest benefits of applying the Lorentz style in human life is the Bedini SSG. Bedini SSG is a type of motor magnetic generator created and shown by John Bedini. When Bedini SSG is electrified, there will be a current flowing towards the commutator ring. Then, by means of a carbon brush current flowing into the coil, in the motor Bedini SSG, there is a magnet that creates a magnetic field, in result the magnetic field and electric current flows to cause a circular motion due to the Lorentz force [3].



In Figure 1 shows a unit of Bedini SSG consisting of a wheel rotor with 24 permanent magnets attached in the direction of the North Pole to the rotor. Coils with 8 separate strands of wires are wrapped together with a circuit consisting of 7 transistors, 7 resistors, 14 diodes, and 7 Neon Bulbs. The frame holder for wheels and all its components are made of wood because wood is not affected by the magnetic field of the wheel rotors or coils. The dimensions for wheel rotors are not required to have a certain size, the important thing is that the rotors are perfectly round, balanced, and can rotate well with low friction against the bearings,



Figure 1. Bedini SSG based on the original design.

Using the same system and way of working, a smaller capacity of the Bedini SSG circuit scheme is shown in Figure 2. Figure 2 uses batteries and transistors with characteristics that have a smaller capacity compared to Bedini SSG in Figure 1.

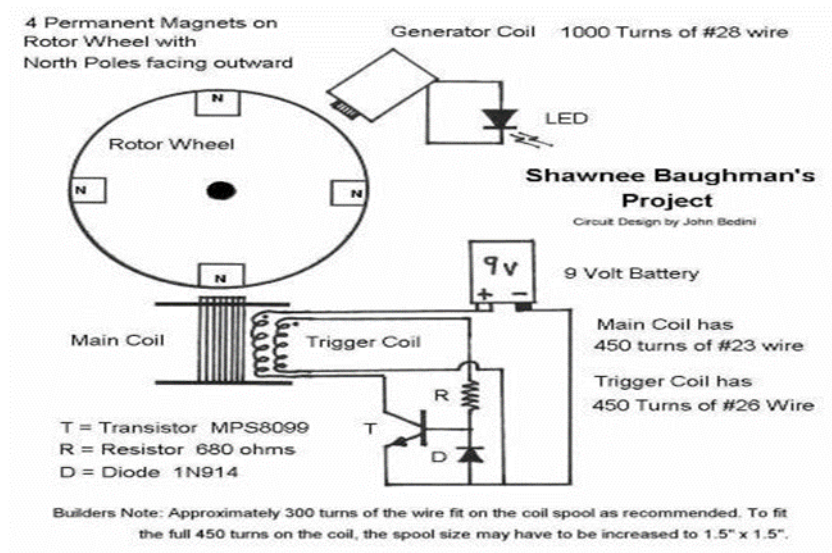

Figure 2. Bedini SSG series scheme.

The Bedini SSG generally is used for electric motorbike. This is based on the fact that the system operates with electricity and the wheels rotate as long as the system works. Motors are usually designed with a certain power to operate on several devices such as pumps or compressors. The Bedini SSG is similar to an electric motor but is different because the SSG rotating bed produces limited mechanical power. The real purpose of this device has a very specific effect on battery power and the way it keeps the rotor spinning by itself [4,5].

3. Magnet

Magnets can be made from iron, steel, and a mixture of metals, magnets have also been widely used for the automotive industry and others. A magnet consists of small magnets that have the same direction (arranged regularly), these small magnets are called elementary magnets. In metals that are not magnets, the elementary magnet has a random direction so that the effects cancel each other out, which results in the absence of magnetic poles on the metal end. Each magnet has two poles, namely: north (N) and south (S). The magnetic pole is an area that is at the ends of a magnet with the greatest magnetic force at its poles.

The use of neodymium magnets at Bedini SSG has better efficiency and lower prices compared to the original Bedini SSG [6]. The most permanent characteristic of a permanent magnet is Neodymium Iron Boron (NdFeB), NdFeB is a permanent type of rare earth magnetic material, this is because it is formed by 2 atoms of a rare earth metal element Neodymium (Nd), 14 atoms of iron (Fe) and 1 Boron atom (B), so the molecular formula formed is $\text{Nd}_2\text{Fe}_{14}\text{B}$ and the magnetic properties that are very well possessed with BHmax range from 30 Mega Gauss Oersted (MGOe) to 52 MGOe [6]. The main element forming the NdFeB magnet is Iron (Fe) with a composition of 60.36%, Neodymium (Nd) of 32.53%, and Boron of 7- 14%. Other elements included are Silicon (Si) of 3.42% and Cobalt (Co) of 3.69%. The Si and Co elements in NdFeB magnets are additives that can function to enhance magnetic properties such as; remanent induction, maximum coercivity and energy products. Besides this, additives can also no need of "be". increase corrosion resistance curie temperature. Figure 3 shows the type of magnet used.



Figure 3. Types of magnet.

4. Battery

A battery is a device that can store chemical energy and make it electrical energy when needed. The electricity produced by a battery arises due to the potential difference in the electrical energy of the two electrodes. This potential difference is known as cell potential or electromotive force (emf). To complete the reaction in a battery, the charge and outer circuit transfer media are needed as an electric flow line. Batteries used today have a big difference with early generation batteries. In terms of construction, early generation batteries have large sizes and have components that are prone to damage. The batteries being used today and most of the components are solid, making it safer. In terms of energy capacity, batteries being used now have a ratio of energy to mass which is far greater than that of early generation batteries. Based on its ability to be discharged and recharged, batteries are divided into two, namely the Primary Battery and the Secondary Battery. The ability or inability of a battery to be recharged lies in the chemical reaction in the battery. The definition of refill is to reverse the chemical reaction that occurs in a battery by applying an electric current to a certain potential. In the secondary battery the reversing reaction can occur, whereas in the primary battery, reversing the reaction cannot occur.

5. EMF

EMF reverse or reverse electric force is the reverse of voltage generated by the BLDC motor winding, when the BLDC motor rotates it has a voltage polarity opposite to the source voltage generated [7-12]. The magnitude of the return EMF is influenced by the speed of the motor rotation angle (ω), the magnetic field produced by the rotor (B), and the number of turns in the stator winding (N), to conclude, the magnitude of the reverse EMF can be calculated by the equation:

$$V = i R + EMF \quad (1)$$

$$\text{Back EMF} = B.N.l.r.\omega \quad (2)$$

6. The proposed method

In the research that will be carried out there are a series of steps that must be passed in order to achieve the expected research objectives. The stages in this study in broad outline include:

First, in this stage the things that need to be considered are estimating what components will be used to test the radiant charging by using 5 coils and 5 poles neodymium magnet as a rotor drive. The second stage is literature study, the initial stage of this research is looking for literature from the results of previous researches, books and the internet to find out the characteristics, work principles and theories that support the research. It is expected that the obtained literature can provide clues and can be used as a theoretical basis in research. The third stage is to design a Radiant charger prototype by using 5 coils and 5 permanent magnets as well as testing the resulting tool. The fourth stage is making tools, the making of tools is adjusted to what was planned in the initial step of the research, starting from the form of tools to the installation of the coil, the diameter of the coil that will be used, the number of turns, and the permanent magnet used. The fifth stage is data collection, includes the rotation of the rotor, in rpm unit, and the power generated by the radiant charger, in volt ampere unit. The sixth stage is analyzing data, data analysis is carried out after obtaining the results of data from the data obtained, namely how the number of coils and permanent magnets influence the rotor rotation produced and the rotational speed of the rotor on the voltage produced. The Final Stage is to conclude, conclusions are taken from the results of the analysis that has gone through several tests so that the results are based on the objectives of the study, namely the rotational speed of the rotor, and the output voltage obtained.

7. Design of a radiant charger using 5 coils and 5 poles of neodymium magnet as a rotor drive

Figure 4 and Figure 5 shows the design of a radiant charger using 5 coils and 5 poles of neodymium magnet as a rotor drive. When the rotor rotates, the magnetic pole begins to move closer to the iron core coil. The trigger coil is induced but the direction of the current generated is not suitable for activating the transistor on, because of that the transistor remains in the off position as long as the magnet moves closer to the iron core coil. When the magnet is right above the iron core coil, the iron core reaches the maximum inductance and the magnetic flux changes stop because there is no current flowing. At this point, the magnet induces the iron core, as a bar magnet with the south pole facing the rotor magnet and the north pole is back to back with the rotor magnet. As a result, the rotor starts to spin.

The iron core magnetic field begins to drop and result in a change of magnetic flux making the induction stand on the core coil with the direction of the current opposite from the previous direction. This current activates the transistor on the condition in which causes the current to flow towards the coil and battery. This condition makes the iron core coil electromagnetic with the north pole facing the rotor, so that a repulsive force occurs against the magnet and the rotor is pushed to spin.



Captions :

1. Coil
2. Rotor
3. Neodymium Magnet

Figure 4. Design of a radiant charger using 5 coils and 5 poles of neodymium magnet.

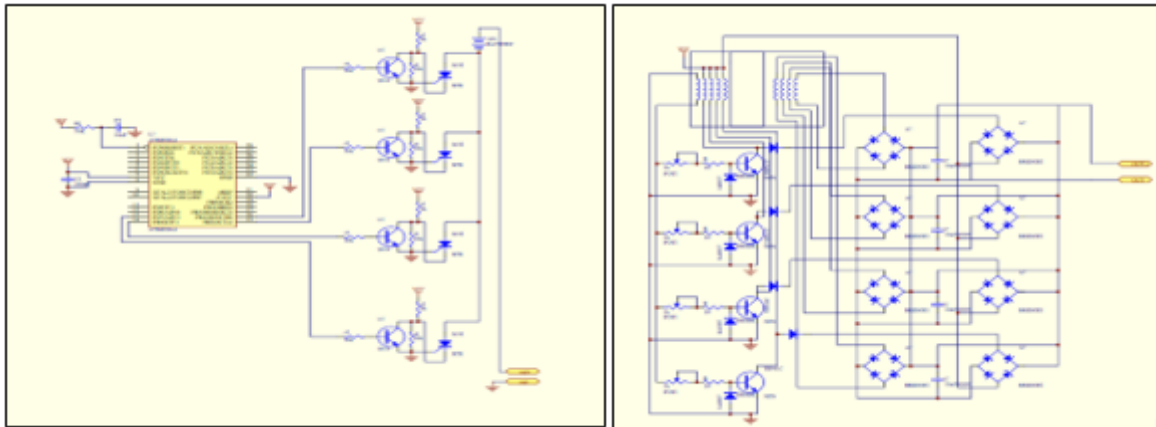

Figure 5. Schematic circuit of a radiant charger using 5 coils and 5 poles of neodymium magnet.

8. Experimental results

Table 1. The results of testing of radiant charger using 5 coils and 5 poles of neodymium magnet.

Rotor rotation (Rpm)	Voltage (V)
20	46
75	298
140	431
176	524
200	600
295	900
309	1000
346	1020

Table 1 shows the results of testing a Radiant Charger Using 5 Coils and 5 Poles of Neodymium Magnet. Vice versa the lower the rotating speed of the rotor is, the lower the voltage generated will be.

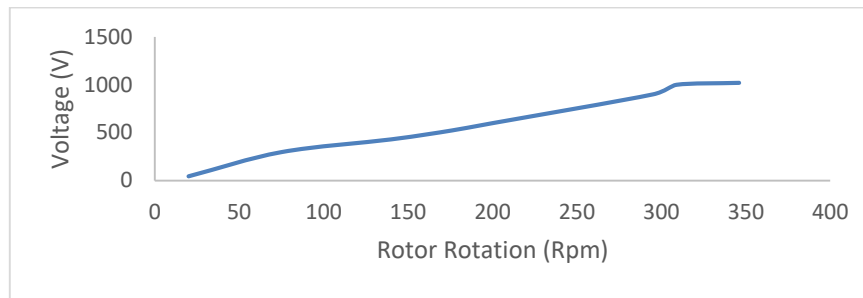

Figure 6. Graph voltage vs. rotor rotation for radiant charger.

Figure 6 shows a graph of the relationship between the rotational speed of the rotor and the voltage produced. So the higher the rotating speed of the rotor is, the higher the voltage generated will be and vice versa the lower the rotating speed of the rotor is, the lower the voltage generated will be.

9. Conclusion

As a conclusion, this project concludes that the higher the rotating speed of the rotor is the higher the voltage generated will be and vice versa if the rotor rotation is lowered then the resulting voltage will also decrease. The results of the design and testing of the device a rotor rotation of 1020 rpm at 346 volts. The higher the rotating speed of the rotor is, the higher the voltage produced will be.

Acknowledgment

The authors would like to thank State Polytechnic of Malang for supporting this research.

References

- [1] Casis M 2013 Free-Energy Generator *Pulsar* **1**
- [2] Neo T Y 2011 Investigation on free energy magnetmotor *UTAR*
- [3] Bedini J C 2003 Device and method for utilizing a monopole motor to create back EMF to charge batteries *Google Patents*
- [4] Bedini J C 2006 Device and method of a back EMF permanent electromagnetic motor generator *Google Patents*
- [5] Bedini J C Motor/Generator [Online] retrieved from <http://www.rexresearch.com/bedini/bedini.htm>
- [6] Kondawar S, Kumar and Poojari R R Bedini wheel Using Electromagnetic Flux Generation *IEJRD* **3(2)**
- [7] Zimm C 2006 Design and performance of a permanent-magnet rotaryrefrigerator *International journal of refrigeration* **29** 1302-1306
- [8] Schauder C 1992 Adaptive speed identification for vector control of induction motors without rotational transducers *IEEE Trans. Ind. Appl.*, **28(5)** 1054–1061
- [9] Holtz J 2006 Sensorless control of induction machines - with or without signal injection? *IEEE Trans. Ind. Electron.*, **53(1)** 7–30
- [10] Khalil H K, Strangas E G and Jurkovic S 2009 Speed observer and reduced nonlinear model for sensorless control of induction motors *IEEE Trans. Control Syst. Technol.*, **17(2)** 327–339
- [11] Kubota H, Matsuse K and Nakano T 1993 DSP- based speed adaptive flux observer of induction motor *IEEE Trans. Ind. Appl.*, **29(2)** 344–348
- [12] Kim S and Sul S 2011 Sensorless control of AC motor — Where are we now? *in Proc. 2011 Int. Conf. Elect. Mach. and Syst. (ICEMS)* 1–6